

FLEMCO Flowmeter

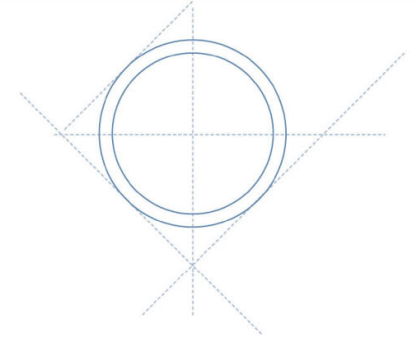

Typical Applications

The FLEMCO flow meters measure the flow of most liquids and gases within the process industries, including chemical, petro-chemical, pharmaceutical and the power industry.

The FLEMCO is based on the principle of measuring velocity in the pipe line, therefore the flow measurement is volumetric.

The FLEMCO flow meters are backed by international standards covering flow calculation, manufacturing tolerances, accuracy and installation requirements. This type of bare bone technology is world wide accepted and supported by millions of successful installations.

Features

The FLEMCO flow meter features are:

Standardised product based on well proven technology.

Compact design.

Simple construction.

Free choice for horizontal or vertical pipe run.

Standardised construction means low inventory.

No moving parts.

Not sensitive to vibrations.

The electronics delivers output signal linear to flow.

Digital indicator for local flow reading.

High accuracy.

Wide rangeability.

Easy to install.

Easy to re-calibrate.

Model with integrated manifold valve.

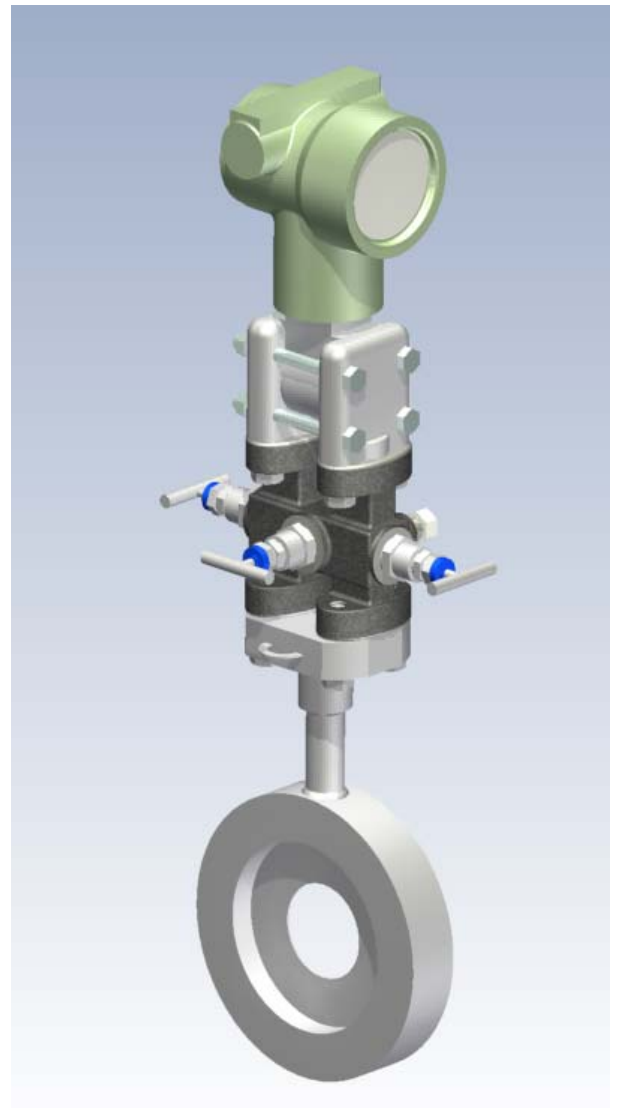

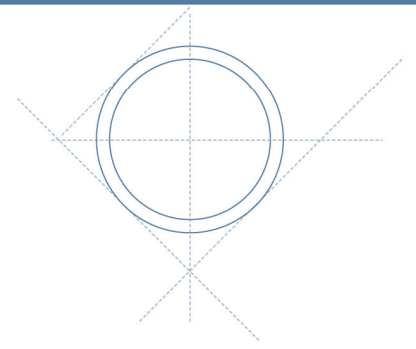

Construction

Model F1

The FLEMCO flow meter model F1 consists of a primary element based on the differential pressure principle and a manifold flange.

Model F2

The FLEMCO flow meter model F2 consists of a primary element based on the differential pressure principle with an integrated 3 valve manifold valve.

Model F5

The FLEMCO flow meter model F5 consists of a primary element based on the differential pressure principle with an integrated 5 valve manifold valve.

The FLEMCO flow meter is mounted between flanges in sizes from DN 40 (1½") to DN 400 (16") in pressure ratings up to PN 40 (300 lbs).

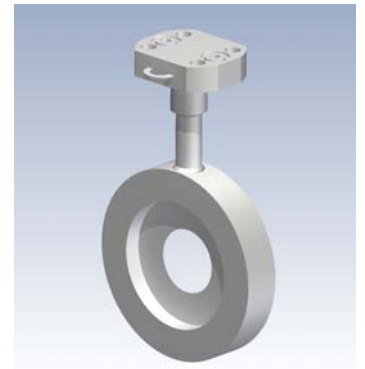

Model F1

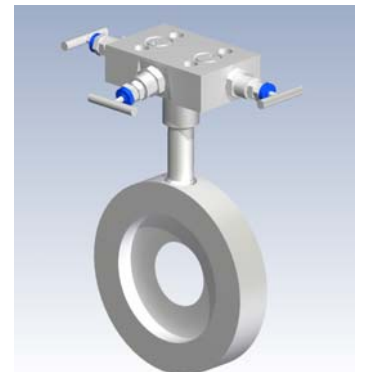

Model F2

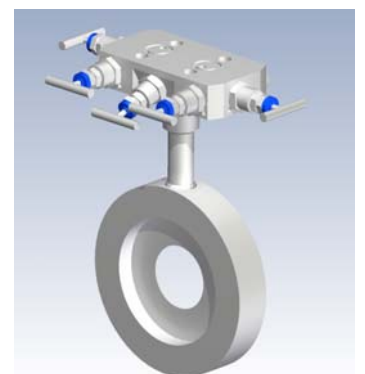

Model F5

Accessories

Remote Mounting Kit type RMK is available if remote mounting of electronics is required in case of not easy accessible pipe line or elevated process temperature.

The customer has to provide the stainless steel instrument tube \varnothing 12 x 1 mm between flow meter and electronics.



Remote electronic indicator with LCD is available for local flow indication and if required check/change of flow rate (differential pressure).

Principle of measurement

The FLEMCO is a velocity flow meter.

A restriction in a pipe line changes the value of the different energies. Based on the law of energy balance developed by Bernoulli the sum of energies remains constant.

Increases the velocity in the pipe line, decreases the pressure in the restriction.

The pressure differential between the inlet pressure and the pressure in the restriction is measured expressing the flow velocity.

When the physical values of the fluid are known and the inner pipe diameter is established the electronics calculate the flow rate. The flow rate is expressed in an analogue signal 4 - 20 mA or signal for digital communication.

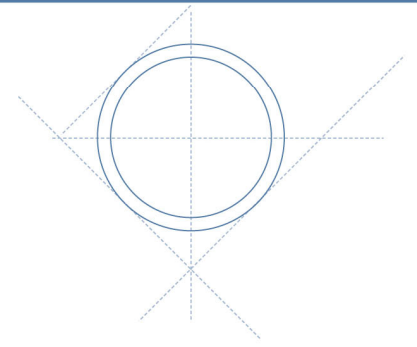

Technical data

Sizes	: DN 40 - DN 400, 1½" - 16", larger sizes on request
Pressure rating	: up to PN 40, 300 lbs, higher pressure ratings on request
Temperature	: Process : -50 - +150°C, higher temperature with Remote Mounting Kit
Mounting style	: Between flanges according to DIN or ANSI standards
Flange facing	: flat face (standard), raised face, DIN 2512 N, DIN 2513 R
Overall length	: 32 mm
Material	: Stainless steel AISI 316, others on request
Design and calculation standards	: ISO 5167, ASME MFC-3M.
Vent or drain hole	: On request
β (d/D)	: 0,5 and 0,6; other β on request.
Accuracy	: +/- 1 %
Rangeability	: 8 : 1
Repeatability	: better than 0,1 %
Pressure loss	: typical 150 mbar for liquid flow, and 50 mbar for gas flow (values are given at full flow)
Reynolds No	: Re > 5000
Allowable differential pressure	: max 2,5 bar
Output signal	: analogue 4 - 20 mA or Digital communication via protocol, HART, PROFIBUS, Fieldbus Foundation or others.
Local indicator (option):	LCD showing flowing units or %
Power supply	: 14 - 36 Vdc, typical 24 Vdc.
Max load (24 Vdc)	: 700 Ohm
Enclosure	: IP 67
Ex protection	: intrinsically safe EEx ia IIC T6, Explosion proof EEx d IIC T6
Temperature	: Ambient : -40 - +80°C

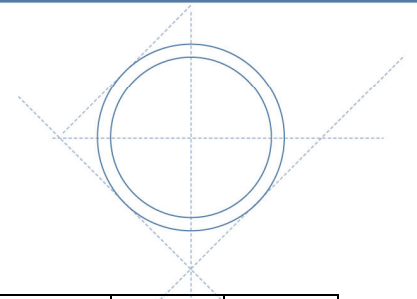

Sizes

DIN flanges

Size	Pipe OD	Pressure rating	Inner pipe diameter	$\beta = 0,5$ Bore	$\beta = 0,6$ Bore	B	A1	A2
DN 40	48,3	PN 40	43,1	21,5	26,0	90	147	157
DN 50	60,3	PN 40	54,5	27,3	32,0	107	156	166
DN 65	76,1	PN 40	70,3	35,0	42,0	127	166	176
DN 80	88,9	PN 40	82,5	41,0	49,5	142	173	183
DN 100	114,3	PN 16	107,1	54,0	64,0	162	183	193
DN 100	114,3	PN 40	107,1	54,0	64,0	168	186	196
DN 125	139,7	PN 16	131,7	66,0	79,0	192	198	208
DN 125	139,7	PN 40	131,7	66,0	79,0	194	199	209
DN 150	168,3	PN 16	159,3	80,0	96,0	218	211	221
DN 150	168,3	PN 40	159,3	80,0	96,0	224	214	224
DN 200	219,1	PN 16	207,3	104,0	124,4	273	239	249
DN 200	219,1	PN 25	206,5	104,0	124,4	284	244	254
DN 200	219,1	PN 40	206,5	104,0	124,4	290	247	257
DN 250	273	PN 16	260,4	130,0	156,0	329	267	277
DN 250	273	PN 25	258,8	130,0	156,0	340	272	282
DN 250	273	PN 40	258,8	130,0	156,0	352	278	288
DN 300	323,9	PN 10	309,7	155,0	185,0	378	291	301
DN 300	323,9	PN 16	309,7	155,0	185,0	384	294	304
DN 300	323,9	PN 25	307,9	155,0	185,0	400	302	312
DN 300	323,9	PN 40	307,9	155,0	185,0	417	311	321
DN 350	355,6	PN 10	341,4	170,0	204,0	438	321	331
DN 350	355,6	PN 16	339,6	170,0	204,0	444	324	334
DN 350	355,6	PN 25	339,6	170,0	204,0	457	331	341
DN 350	355,6	PN 40	338,0	170,0	204,0	474	339	349
DN 400	406,4	PN 10	392,2	195,0	234,0	489	341	351
DN 400	406,4	PN 16	390,4	195,0	234,0	495	350	360
DN 400	406,4	PN 25	388,8	195,0	234,0	514	359	369
DN 400	406,4	PN 40	384,4	195,0	234,0	546	375	385

ANSI flanges

Size	Pipe OD	Pressure rating	Sch. 10S	Sch. 40	Sch. 80	$\beta = 0,5$ Bore	$\beta = 0,6$ Bore	B	A1	A2
			Inner pipe dia.	Inner pipe dia.	Inner pipe dia.					
1½"	48,3	150 lbs	42,7	40,9	37,3	20,0	24,0	85,7	145	155
		300 lbs						95,3	150	160
2"	60,3	150 lbs	54,7	52,5	49,3	26,0	31,5	104,8	154	164
		300 lbs						111,1	158	168
3"	88,9	150 lbs	82,8	77,9	73,7	39,0	47,0	136,5	170	180
		300 lbs						149,1	177	187
4"	114,3	150 lbs	108,2	102,3	97,2	51,0	61,0	174,6	189	199
		300 lbs						181,1	193	203
6"	168,3	150 lbs	161,5	154,1	146,3	77,0	92,5	222,3	213	223
		300 lbs						250,7	227	237
8"	219,1	150 lbs	211,5	202,7	193,7	101,0	121,6	279,4	242	252
		300 lbs						308	256	266
10"	273	150 lbs	264,6	254,5	242,8	127,0	153,0	339,7	272	282
		300 lbs						362	283	293
12"	323,9	150 lbs	314,7	303,2	289,1	150,0	180,0	409,6	307	317
		300 lbs						422,3	313	323
14"	355,6	150 lbs	346	333,3	317,5	165,0	198,0	450,9	327	337
		300 lbs						485,8	345	355
16"	406,4	150 lbs	396,8	381	363,6	190,0	228,0	514,4	359	369
		300 lbs						539,8	372	382

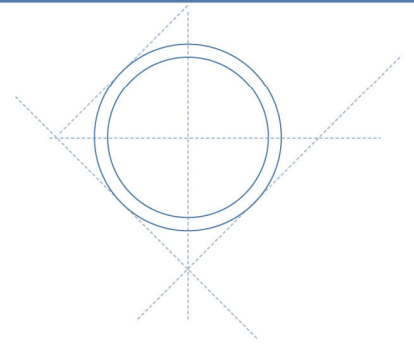

Overall dimensions

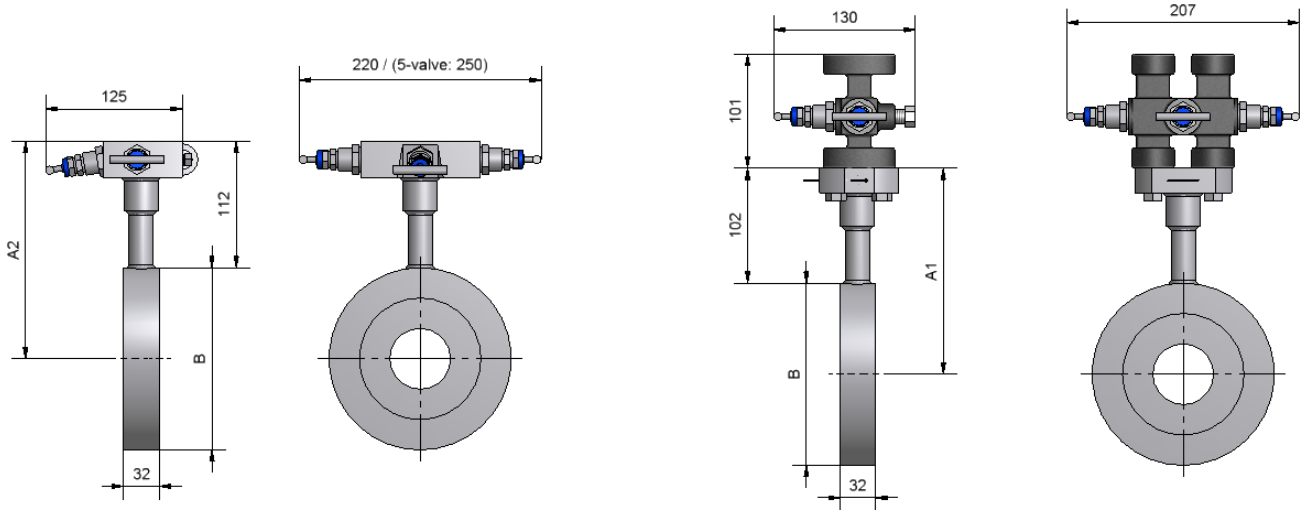

Installation requirements

The FLEMCO flow meter can be mounted in a horizontal or vertical pipe. For liquid flow in a horizontal pipe the electronics shall be mounted below the pipe. For gas flow in a horizontal pipe the electronics shall be mounted above the pipe.

To insure high accuracy of measurement, long straight pipe runs upstream from the flow meter is necessary. The required straight pipe run depends on the disturbance upstream. To maintain the 1% accuracy the minimum straight pipe run upstream shall be 14 x inner pipe diameter and 6 x downstream. If an additional inaccuracy of ½ % is acceptable the required straight pipe runs are reduced to half of the above values.

Is mass flow required due to changing process conditions ask for the ORIMAS mass flow meter data sheet. Saturated and superheated steam is covered by STEEMCO flow meters

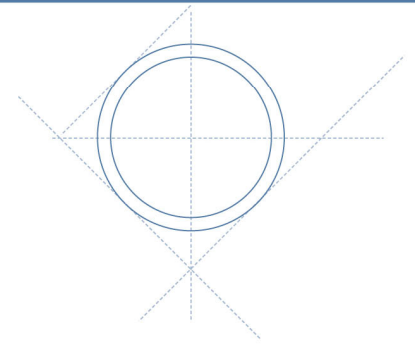

FLEMCO coding

1. Type

In AISI 316 with transmitter flange	code	F1
integrated 3 valve manifold	code	F2
integrated 5 valve manifold	code	F5

2. Size

DN 40, DIN standard	code	040
DN 50, DIN standard	code	050
DN 65, DIN standard	code	065
DN 80, DIN standard	code	080
DN 100, DIN standard	code	100
DN 125, DIN standard	code	125
DN 150, DIN standard	code	150
DN 200, DIN standard	code	200
DN 250, DIN standard	code	250
DN 300, DIN standard	code	300
DN 350, DIN standard	code	350
DN 400, DIN standard	code	400
1½", ANSI standard	code	01.5
2", ANSI standard	code	002
3", ANSI standard	code	003
4", ANSI standard	code	004
6", ANSI standard	code	006
8", ANSI standard	code	008
10", ANSI standard	code	010
12", ANSI standard	code	012
14", ANSI standard	code	014
16", ANSI standard	code	016

3. Pressure rating

PN 10, DIN standard	code	10
PN 16, DIN standard	code	16
PN 25, DIN standard	code	25
PN 40, DIN standard	code	40
150 lbs, ANSI standard	code	15
300 lbs, ANSI standard	code	30

4. Facing

DIN 2526 Form A	code	26
DIN 2513 Form R13	code	13
DIN 2512 Form N	code	12
Raised face RF, ANSI std.	code	RF
Flat face FF, ANSI std.	code	FF

Remote mounting kit type RMK is ordered separately.

5. Pipe schedule (only applicable for ANSI flanges)

DIN flanges	code	00
Schedule 10S	code	10
Schedule 40	code	40
Schedule 80	code	80

6. β value

β value 0,5	code	5
β value 0,6	code	6
β value free choice	code	9

7. Drain/vent hole Ø3 mm

Without drain/vent hole	code	0
With drain/vent hole	code	1

8. manifold valve

F1 - Without	code	0
F1 - 3 valve manifold	code	1
F2 - Integrated 3 valve	code	2
F5 - Integrated 5 valve	code	5

9. Differential pressure transmitter

Without	code	0
Included	code	Original transmitter type no.

Examples

DN 100 FLEMCO F1 in stainless steel PN 40 with DIN 2526 facing, β value 0,6, without drain/vent hole and with 3 valve type G3H double flanged manifold valve and without transmitter has following code:

F1-100-40-26-00-6-0-1-0

8" FLEMCO in stainless steel 150 lbs with RF facing with β value 0,5, with drain/vent hole, with integrated 3 valve manifold and Yokogawa differential pressure transmitter type EJX 110A has following code:

F2-008-15-RF-40-5-1-2-EJX110A