

**Model OR8ERG
KCI Refillable type ORP Sensor**

IM 12C04K01-01E



INTRODUCTION

This manual covers the OR8ERG KCl Refillable type ORP Sensor.

Other related items are described in the following manuals.

Model	Title	IM No.
PH8HG	Guide-pipe Holder	IM 12B7M2-01E
PH8HF, PH8HFF	Flow-Through Type Holder	IM 12B07N01-01E
PH8HS, PH8HSF	Submersion Type Holder	IM 12B07M01-01E
HH350G	Well Bucket Type Holder	IM 19H1B1-01E
PB350G	Float Type Holder	IM 19H1E1-01E
PB360G	Vertical Type Float Holder	IM 19H1E2-01E
FLXA402	4-Wire Converter	IM 12A01F01-02EN IM 12A01F02-01EN etc.
FLXA202, FLXA21	2-Wire Liquid Analyzer	IM 12A01A03-01EN
WTB10-PH□	Terminal Box	IM 19D01B01-01E
OR8AX	Accessories for ORP Meter	IM 12C04W02-01E

◆ For the safe use of this equipment

■ Notes on Handling User's Manuals

- Please hand over the user's manuals to your end users so that they can keep the user's manuals on hand for convenient reference.
- Please read the information thoroughly before using the product.
- The purpose of these user's manuals is not to warrant that the product is well suited to any particular purpose but rather to describe the functional details of the product.
- No part of the user's manuals may be transferred or reproduced without prior written consent from YOKOGAWA.
- YOKOGAWA reserves the right to make improvements in the user's manuals and product at any time, without notice or obligation.
- If you have any questions, or you find mistakes or omissions in the user's manuals, please contact our sales representative or your local distributor.

■ Safety, Protection, and Modification of the Product

- In order to protect the system controlled by the product and the product itself and ensure safe operation, observe the safety precautions described in this user's manual. We assume no liability for safety if users fail to observe these instructions when operating the product.
- If this instrument is used in a manner not specified in this user's manual, the protection provided by this instrument may be impaired.
- If any protection or safety circuit is required for the system controlled by the product or for the product itself, prepare it separately.
- Be sure to use the spare parts approved by Yokogawa Electric Corporation (hereafter simply referred to as YOKOGAWA) when replacing parts or consumables.
- Modification of the product is strictly prohibited.
- The following safety symbols are used on the product as well as in this manual.



WARNING

This symbol indicates that an operator must follow the instructions laid out in this manual in order to avoid the risks, for the human body, of injury, electric shock, or fatalities. The manual describes what special care the operator must take to avoid such risks.



CAUTION

This symbol indicates that the operator must refer to the instructions in this manual in order to prevent the instrument (hardware) or software from being damaged, or a system failure from occurring.

CAUTION

This symbol gives information essential for understanding the operations and functions.

NOTE

This symbol indicates information that complements the present topic.

■ Warning and Disclaimer

The product is provided on an "as is" basis. YOKOGAWA shall have neither liability nor responsibility to any person or entity with respect to any direct or indirect loss or damage arising from using the product or any defect of the product that YOKOGAWA can not predict in advance.

◆ After-sales Warranty

- **Do not modify the product.**

- **During the warranty period, for repair under warranty consult the local sales representative or service office. Yokogawa will replace or repair any damaged parts. Before consulting for repair under warranty, provide us with the model name and serial number and a description of the problem. Any diagrams or data explaining the problem would also be appreciated.**
 - If we replace the product with a new one, we won't provide you with a repair report.
 - Yokogawa warrants the product for the period stated in the pre-purchase quotation. Yokogawa shall conduct defined warranty service based on its standard. When the customer site is located outside of the service area, a fee for dispatching the maintenance engineer will be charged to the customer.

- **In the following cases, customer will be charged repair fee regardless of warranty period.**
 - Failure of components which are out of scope of warranty stated in instruction manual.
 - Failure caused by usage of software, hardware or auxiliary equipment, which Yokogawa Electric did not supply.
 - Failure due to improper or insufficient maintenance by user.
 - Failure due to modification, misuse or outside-of-specifications operation which Yokogawa does not authorize.
 - Failure due to power supply (voltage, frequency) being outside specifications or abnormal.
 - Failure caused by any usage out of scope of recommended usage.
 - Any damage from fire, earthquake, storms and floods, lightning, disturbances, riots, warfare, radiation and other natural changes.

- **Yokogawa does not warrant conformance with the specific application at the user site. Yokogawa will not bear direct/indirect responsibility for damage due to a specific application.**

- **Yokogawa Electric will not bear responsibility when the user configures the product into systems or resells the product.**

- **Maintenance service and supplying repair parts will be covered for five years after the production ends. For repair for this product, please contact the nearest sales office described in this instruction manual.**

Model OR8ERG KCl Refillable type ORP Sensor

IM 12C04K01-01E 10th Edition

CONTENTS

- ◆ INTRODUCTION.....i
- ◆ For the safe use of this equipment.....ii
- ◆ After-sales Warrantyiii
- 1. Specification 1-1
 - 1.1 Standard Specifications..... 1-1
 - 1.2 Model and Suffix codes..... 1-2
 - 1.3 External Dimensions 1-3
- 2. Installation..... 2-1
 - 2.1 Preparation for Installation 2-1
 - 2.1.1 Unpacking and Inspection 2-1
 - 2.1.2 Installing Holder 2-1
 - 2.1.3 Installing Associated Instruments 2-1
 - 2.2 Requirements for mounting the ORP Sensor..... 2-2
 - 2.2.1 In case of installing the PH8HG Guide-pipe Holder 2-2
 - 2.2.2 Installing Sensor in PH8HS Submersion Holder 2-3
 - 2.2.3 Installing Sensor in PH8HF Flow-through Holder..... 2-6
 - 2.3 ORP Sensor Cable Wiring Procedure..... 2-7
 - 2.3.1 Connecting Sensor Cable to Terminal Box..... 2-7
 - 2.3.2 Connecting Sensor Cable to Two-wire ORP Transmitter 2-8
 - 2.3.3 Connecting Sensor Cable to Four-wire ORP Converter 2-9
- 3. Maintenance on operation..... 3-1
 - 3.1 Operation and Periodic Maintenance 3-1
 - 3.1.1 Calibrating ORP Sensor Using Checking Solutions..... 3-1
 - 3.1.2 Cleaning Indicator Electrode and Liquid Junction 3-1
 - 3.1.3 Refilling Sensor with KCl Solution 3-1
 - 3.2 Replacing Consumable Parts..... 3-3
 - 3.2.1 Replacing Liquid Junction 3-3
- Customer Maintenance Parts List.....CMPL12C03K01-01E
- Revision Informationi

1. Specification

The Model OR8ERG KCl Refillable ORP Sensor features maintainability which involves no KCl solution coming out of the liquid junction.

This sensor can be mounted on either an PH8HF flow-through holder or an PH8HS submersion holder. The sensor can be submerged up to a maximum of 3 meters.

1.1 Standard Specifications

Measurement: Oxidation-reduction potential of a solution

Measurement principle: Metallic electrode method

Measuring range: -1500 to 1500 mV

Installation: Mounting in PH8HS submersion holder

Mounting in PH8HG guide-pipe holder

Mounting in PH8HF flow-through holder

Note: If any of the following solutions are measured, install the sensor either in a flow-through or submersion holder.

- A strong acid solution is to be measured (e.g., aqua regia, chromic acid, hypochlorous acid or perchloric acid, etc.).
- The solution contains corrosive gases (e.g., ammonia, chlorine, hydrogen sulfide, etc).
- The solution contains a small percentage of organic solvent or oil.

Solution temperature : -5 to 80°C (refer to Table 1)

Table 1. Process Temperature Range

Holder Type	Holder Material	Cleaner	Solution pH Range	Solution Temperature (°C)
Guide-pipe (PH8HG)	PVC	None	2 to 12	-5 to 50
	PP	None		-5 to 80
Submersion (PH8HS) Flow-through (PH8HF)	PP, SS (*1)	None, Provided		-5 to 80
Well Bucket (HH350G)	SS (*1)	None, Provided		-5 to 80
Float (PB350G, PB360G)	PP, SS (*1)	None		-5 to 50

Note: PVC: Rigid Polyvinyl, PP: Polypropylene, SS: Stainless Steel

*1: Stainless steel holder and Stainless steel adapter should be used when the pH value of the solution is pH3 or more acidic.

Solution pressure : under atmospheric pressure to 50 kPa, when using a holder, refer to Table 2.

Table 2. Process Pressure Range

Holder	Process Pressure Range
Submersion	Atmospheric pressure (Submersion depth: Max. 3 m)
Guide-pipe Suspension Float	Atmospheric pressure (Submersion depth: Max.3 m)
Flow-through	Atmospheric pressure to 50 kPa

Note: For flow-through types, refer also to the solution temperature and pressure diagram of Holder IM.

Operating solution depth: 3 m water pressure (max.) under atmospheric pressure

Solution flow velocity: 2 m/s max.

Solution flow rate: 3 to 11 L/min (when the sensor is installed in a flow-through type holder).

Wetted part materials:

Body; Ryton (PPS resin), platinum-glass or gold-epoxy resin, titanium, ceramics, Fluoro rubber (FKM) or Perfluoroelastomer (FFKM)

Cable; Chlorinated polyethylene rubber (Cable sheath)

Weight: Approx. 0.4 kg (Body)

CAUTION



Select the material of wetted parts with careful consideration of process characteristics. Inappropriate selection may cause leakage of process fluids, which greatly affects facilities. Considerable care must be taken particularly in the case of strongly corrosive process fluid such as hydrochloric acid, sulfuric acid, hydrogen sulfide, and sodium hypochlorite. If you have any questions about the wetted part construction of the product, be sure to contact Yokogawa.

1.2 Model and Suffix codes

● ORP Sensor

Model	Suffix Code	Option Code	Description
OR8ERG	KCl Refillable Type ORP Sensor
Electrode	-AU -PT	Gold Platinum
Cable Length	-03 -05 -07 -10 -15 -20	3 m 5 m 7 m 10 m 15 m 20 m
Measuring System	-N -E -F -B -G	For OR200, OR400 (*1) For FLXA402, PH202, FLXA202, FLXA21 (*2) For FLXA202, FLXA21 (*3) For OR100 (*4) For FLXA402, PH450G, PH202/TB (*5)
Style	*A	Style A
Option	O-ring Degreasing treatment Material Certificate	/PF /DG1 /MC1	Perfluoroelastomer (FFKM) (*6) Oil-free finish wetted part With a material certificate of Solution Ground Tip

- *1: Mark band is shown by alphanumeric and fork terminals are used.
- *2: Mark band is shown by numeral and pin terminals are used. When terminal box is used, select WTB10-PH1.
- *3: Mark band is shown by numeral and M4 ring terminals are used. When terminal box is used, select WTB10-PH5.
- *4: The tag which indicated the color, the sign, and the number is attached to the cable of a sensor.
- *5: Mark band is shown by numeral and M3 ring terminals are used. When terminal box is used, select WTB10-PH3.
- *6: Choose Perfluoroelastomer (FFKM) when this is used in organic solvent, high alkali or high temperature solution.

● Accessories

Model	Suffix Code	Option Code	Description
OR8AX	Accessories for ORP meter (*1)
Style	*A	Style A
Option		/STD /KCLL /KCLP /TMP	Sensor stand (with mounting bracket for 2-inch pipe) KCl solution (one 250 mL polyethylene bottle) KCl powder (three bags, 250 mL solution each) Thermometer (0 to 100°C)

- *1: Including the following:
Two 200 mL polyethylene cups
One cleaning bottle
One pack of quinhydrone reagent powder (three bags, 250 mL solution each)
One 250 mL polyethylene bottle

● Consumables

Part Name		Part Number	Remarks
Indicator electrode	Platinum	K9142TS	One for OR8ERG
		K8022GP	One for OR8ERG/PF
	Gold	K9142TT	One for OR8ERG
		K8022GQ	One for OR8ERG/PF
Junction	General	K9142TH	One for OR8ERG
		K9319QA	One for OR8ERG/PF
KCl solution (3.3mol/L)		K9084LP	Six 250 mL polyethylene bottles
KCl powder (for OR8ERG)		K9020UT	2 bags, 1 bottle of 3.3 mol/L KCl, 1 syringe
Reagent for check	Quinhydrone	K9024EC	3 bags, each for preparation of 250 mL
	Iron	K9024ED	3 bags, each for preparation of 250 mL

1.3 External Dimensions

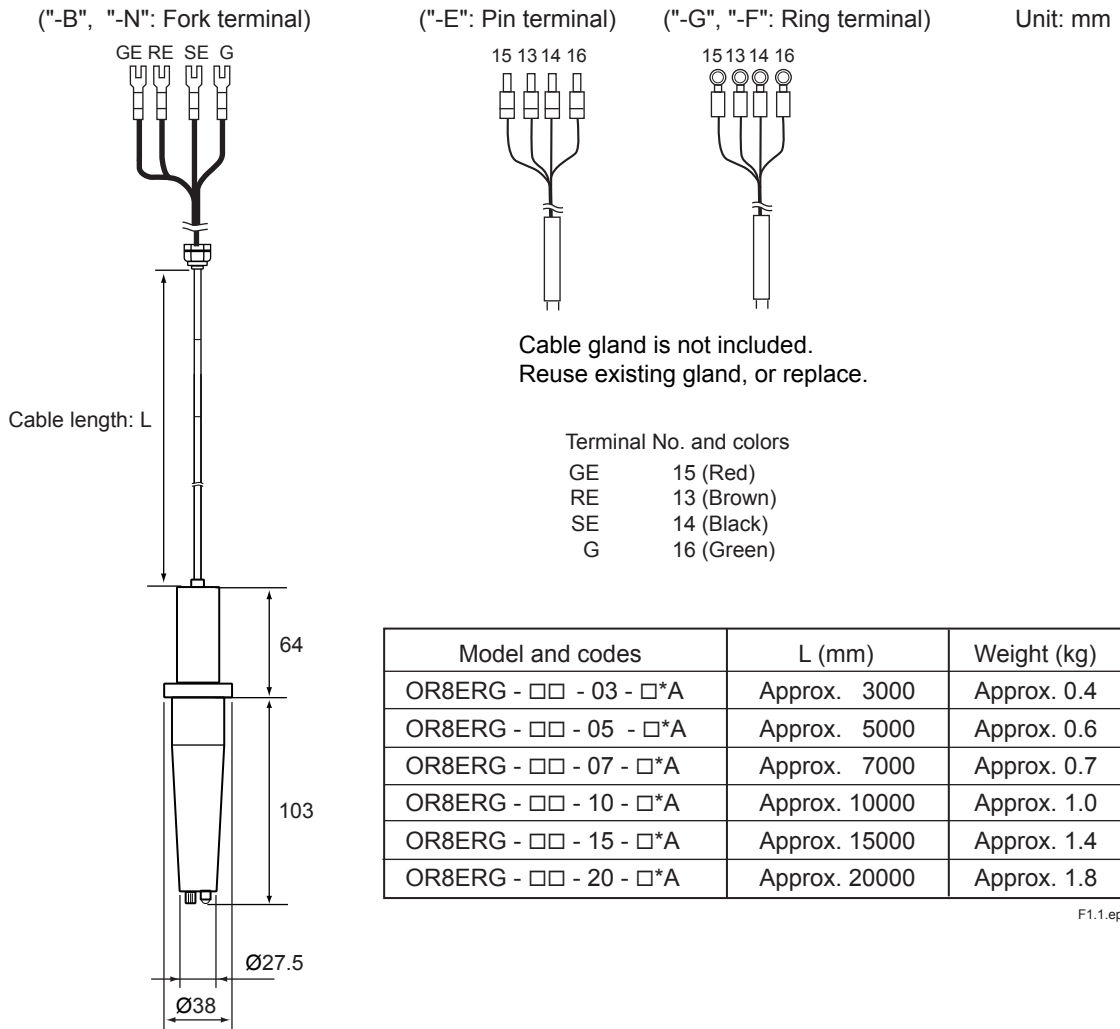

Figure 1.1 OR8ERG Refillable type ORP Sensor

2. Installation

2.1 Preparation for Installation

2.1.1 Unpacking and Inspection

The Model OR8ERG ORP Sensor is packed at the factory to prevent damage during transportation. Upon receipt of the sensor, unpack the shipping container and then visually inspect it for damage. Also check the instrument nameplate on the sensor cable to make sure that you received the correct sensor.

NOTE

Do not attempt to remove the liquid junction (see Figure 2.2 below), Otherwise, the sensor internal solution will leak out. Do not let the liquid junction and indicator electrode dry out. To prevent this, place the protective cap covering the top of the sensor in its original position until the sensor is installed.

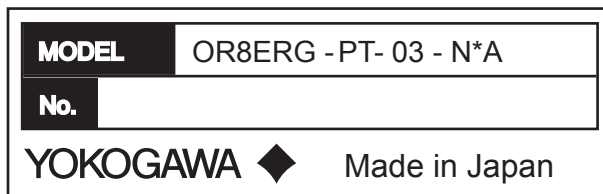

F2.1.ai

Figure 2.1 An Example of Model Number Entering to Nameplate

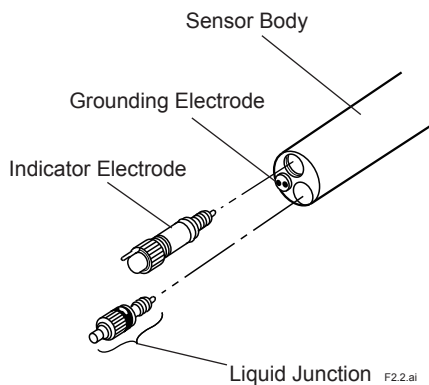

F2.2.ai

Figure 2.2 Names of OR8ERG ORP Sensor Components

2.1.2 Installing Holder

Usually, the ORP Sensor is suspended in a guide pipe or installed in a flow-through or submersion holder. First install the holder.

2.1.3 Installing Associated Instruments

Make sure that the associated instrument (a ORP transmitter/converter or a junction terminal box) to which the ORP Sensor cable is connected has already been installed.

2.2 Requirements for mounting the ORP Sensor

2.2.1 In case of installing the PH8HG Guide-pipe Holder

To install the sensor in the guide pipe, proceed as follows:

- (1) Connect the sensor cable to the associated instrument correctly by referring to Section 2.3 provided later.
- (2) Attach the "stopper" supplied with the guide pipe to the sensor cable.

Fix the sensor cable so that the sensor tip projects 20 to 30 mm out from the pipe end when the ORP Sensor is suspended in the guide pipe as shown in Figure 2.3.

NOTE

If the sensor tip does not project out from the pipe end, the measured value may not respond promptly to the ORP variations of the measured solution. This may cause problems for ORP measurement and control. On the other hand, if the sensor tip projects too far from the pipe end, the force on the sensor may damage the sensor cable from scraping it against the pipe end.

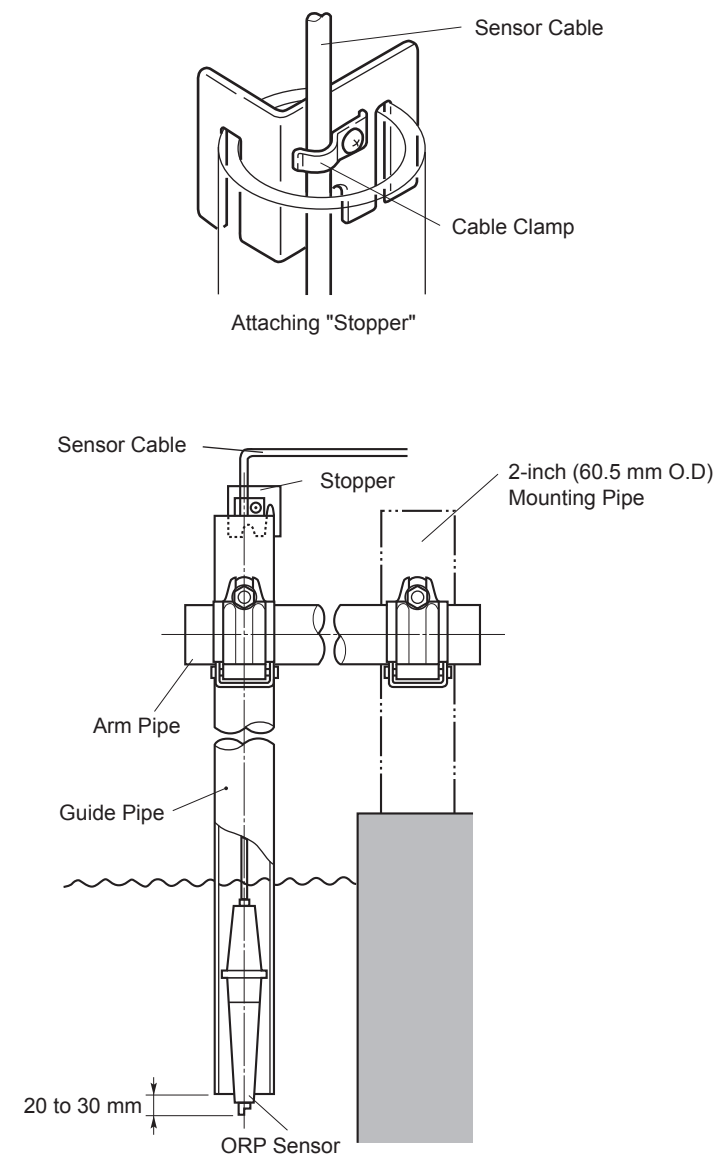
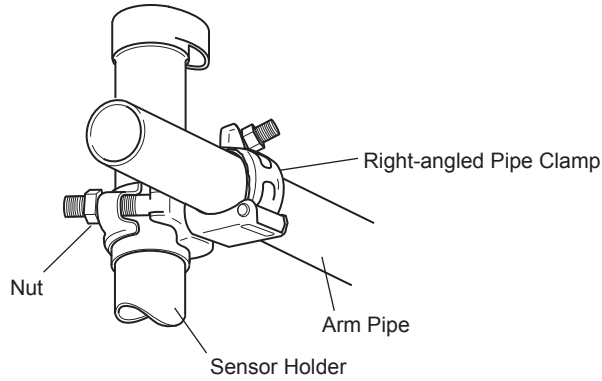

Figure 2.3 Mounting Sensor in Guide Pipe

2.2.2 Installing Sensor in PH8HS Submersion Holder

To install the sensor in the submersion holder, proceed as follows:

- (1) Pass the sensor cable through the sensor holder. If the submersion holder remains installed, remove the sensor holder in any case.
 - For a pipe-mounting submersion holder without a cleaner, loosen the sensor holder nut to remove the holder.



Removal of Sensor Holder (Arm Pipe used with option /MS1 or /MS2)

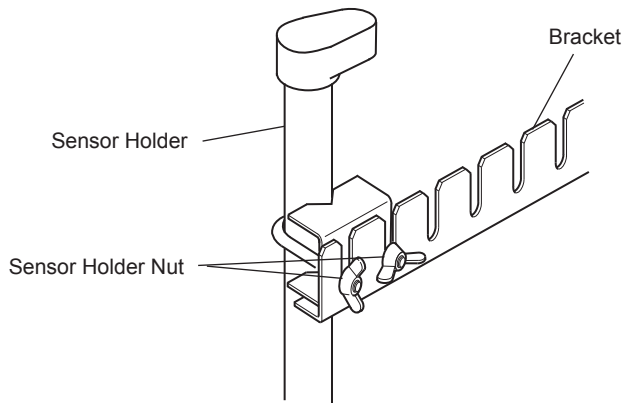

F2.4.ai

Removal of Sensor Holder (Stainless Bracket used with option /MS3 or /MS4)

Figure 2.4 Removal of Sensor Holder (for Pipe Mounting Sensor without Cleaner)

- For a flange mounting submersion holder without a cleaner, remove the sensor holder by loosening the two bolts securing the sensor holder to the flange (see Figure 2.5).

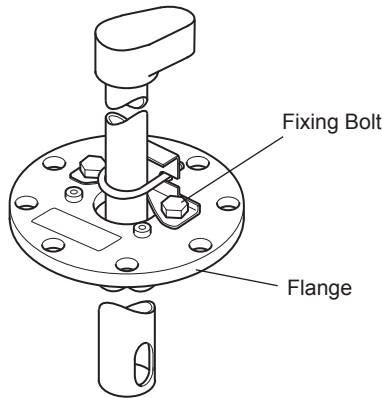

Figure 2.5 Removal of Sensor Holder (for Flange Mounting Sensor without Cleaners)

- To remove the submersion sensor holder with cleaner, whether using pipe mounting or flange mounting type, first loosen the screw of the clamp that retains the cleaner holder and slide up the sensor holder to take it off.

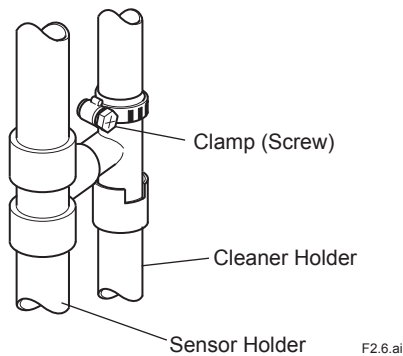

Figure 2.6 Removal of Sensor Holder (with Cleaner)

- (2) Pass the cable and KCl solution supply tube through the sensor holder as follows:
- First, as shown in Figure 2.7, remove the protector screwed into the tip of the sensor holder. After removing it, take away the sponge (material for transportation, not necessary after remove). Pass the sensor cable through the O-ring and attach it to the flange of the sensor. Then, open the waterproof cap cover and insert the sensor cable into the sensor holder pipe.
- When passing the sensor cable through the sensor holder, if dirt or water droplets adhere to the inside of the holder, cover the terminal processing part with a plastic bag or take measures to prevent the decrease in the insulation resistance.
- Pull out the end of the sensor cable downward through the facing-downward hole of the waterproof cap.

For details to install the sensor onto a holder, refer to relevant IMs.

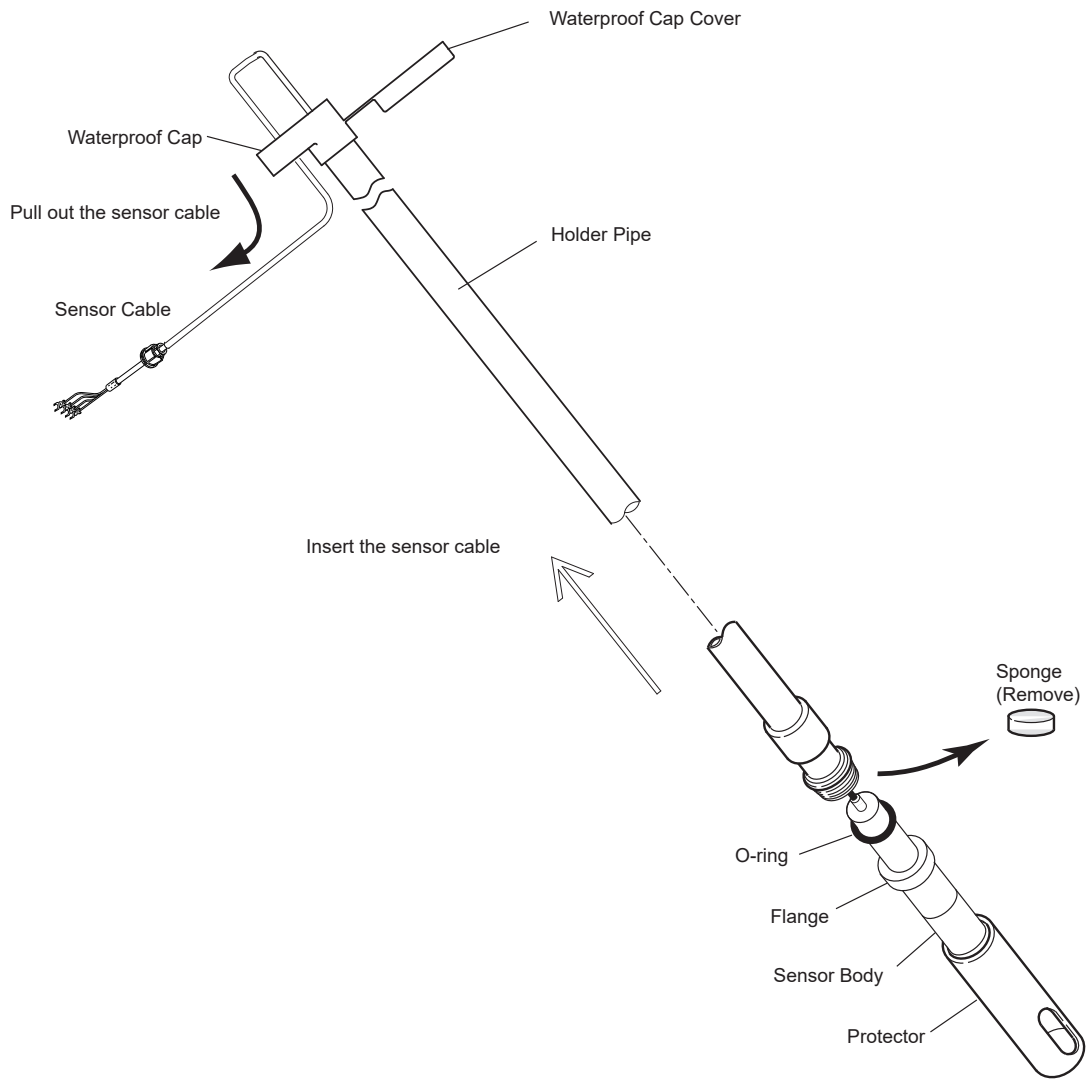

Figure 2.7 Assembling into the sensor holder

- (3) Connect the sensor cable to the associated instrument correctly by referring to Section 2.3.
- (4) Screw the protector to fix the sensor to the holder. In this case, remove the protective cap and secure the protector so that the flange of the sensor compresses the O-ring firmly about the installation method.

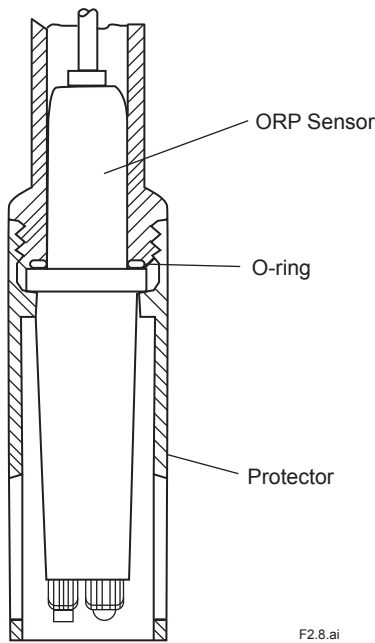

Figure 2.8 Installing Sensor in Submersion Holder

- (5) Close the waterproof cap, and attach the holder to the arm pipe, flange or cleaner holder completely.

2.2.3 Installing Sensor in PH8HF Flow-through Holder

To install the sensor in a flow-through holder, proceed as follows:

- (1) Connect the sensor cable to the associated instrument. First, remove the sensor fixing nut and pass the sensor cable through the nut.

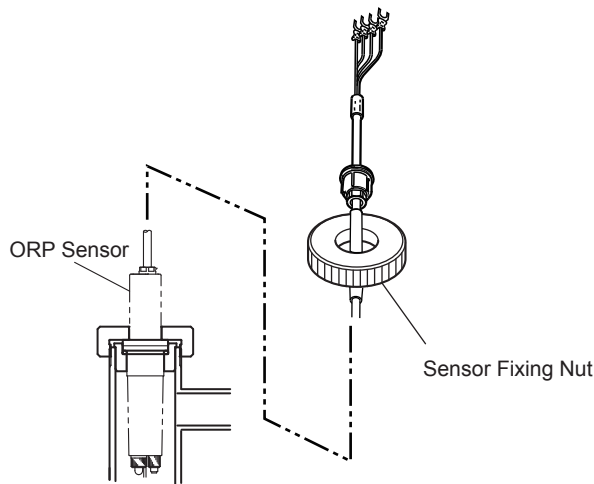

Figure 2.9 Preparation for Sensor Cable Connection

- Properly connect the sensor cable by referring to Section 2.3.
- (2) Connect the ORP Sensor to its holder. Remove the protective cap from the sensor. Also remove the protective foam piece (for shipping - this is not necessary after installing the sensor) from the holder. Be sure that the liquid junction and indicator electrode are mounted properly. Insert the sensor tip into the holder and tighten the sensor fixing nut securely (see Figure 2.10).

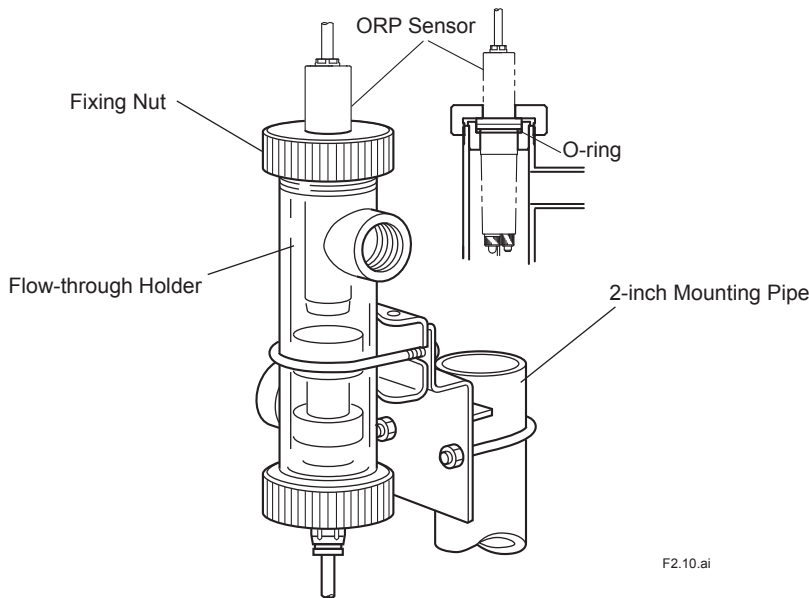

Figure 2.10 Installing Sensor in Flow-through Holder

2.3 ORP Sensor Cable Wiring Procedure

2.3.1 Connecting Sensor Cable to Terminal Box

- (1) Open the cable inlet hole in terminal box using the supplied punch tool. The location of the cable inlet hole is shown by the circle-shaped groove under the case. The end of the supplied punch tool is put in the center of this circle and it is tapped with appropriate force. You can punch out the hole along the groove.

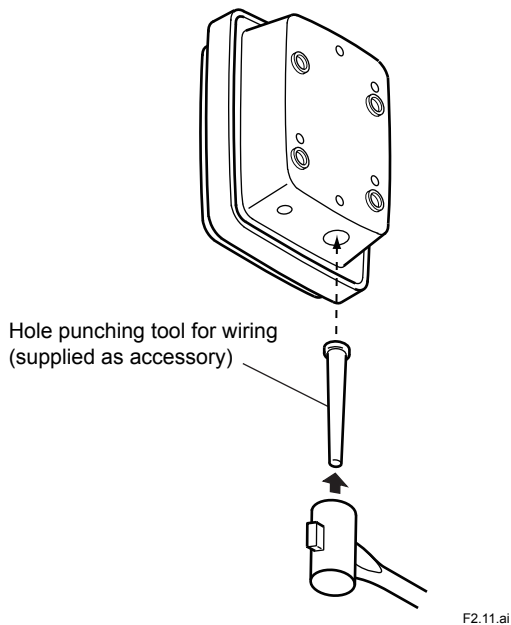

Figure 2.11 How to punch out the wiring hole

- (2) Loosen two screws which are at front of terminal box and detach the cover.
- (3) After detaching the nut from the cable gland of sensor cable, pull the cable into the terminal box from sensor cable inlet hole.
Connect the sensor cable to the terminals.

After passing the cable through the nut, check the symbol on each core wire, then connect each core wire to the corresponding terminal.

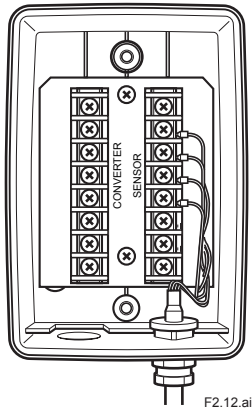

Figure 2.12 Connecting Sensor Cable (In case of the OR8TBG)

- (4) Mount the cable gland in the cable inlet hole as follows:

Put the nut in place, and screw it onto the main body sufficiently. At this time, loosen the cap so that the cable is not twisted. After fixing the main body, tighten the cap to keep moisture out of the equipment. However if the cap is screwed up too tight, the cable will be damaged.

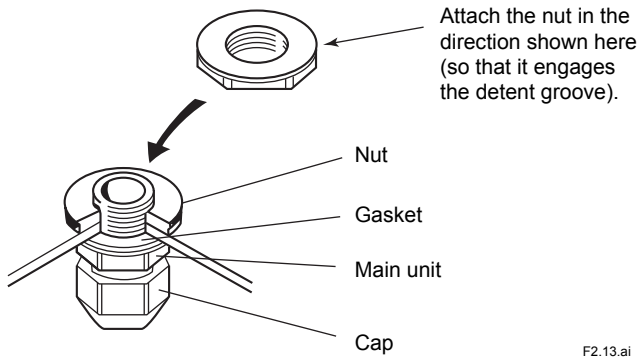

Figure 2.13 Cable Gland

- (5) After completing the cable connections, replace the box cover securely, thus preventing moisture from getting into the case.

2.3.2 Connecting Sensor Cable to Two-wire ORP Transmitter

To connect the sensor cable to the two-wire ORP transmitter, proceed as follows:

- (1) Loosen the four screws that tighten the transmitter cover. Then remove the transmitter cover.
- (2) Connect the sensor cables to the relevant terminals of the transmitter:

First, remove the nut from the cable gland. Insert the cable into the right opening for the wiring. Then pass the cable through the nut, Connect the individual cable conductors to the relevant terminals correctly by referring to the markings on the individual conductors.

For details, refer to relevant transmitter IMs.

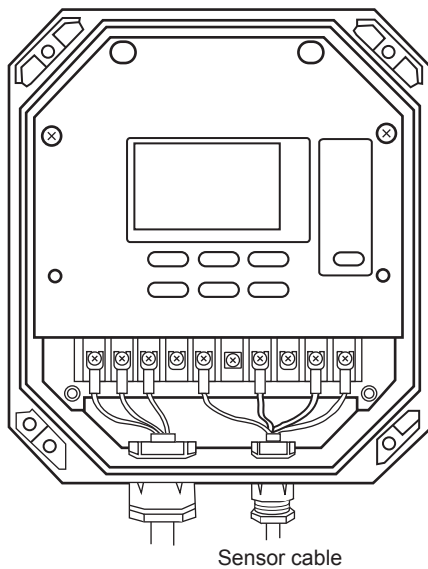

Figure 2.14 Connecting Sensor Cable to Two-wire ORP Transmitter

- (3) Install the cable gland in the wiring hole as follows:
Pass the tip of the cable gland into the opening and completely tighten the gland with the nut inside the case.
After tightening the gland, secure the cap properly to prevent moisture from getting into the case.
Caution: Do not overly tighten the cap. Otherwise, the cable may be damaged.
- (4) After completing the cable connections, replace the transmitter cover securely, thus preventing moisture from getting into the case.

2.3.3 Connecting Sensor Cable to Four-wire ORP Converter

To connect the sensor cable to a Four-wire ORP converter, proceed as follows:

- (1) Loosen the four screws that tighten the converter cover. Then open the converter cover.
- (2) Connect the sensor cables to the relevant terminals of the converter:
First, remove the nut from the cable gland. Insert the cable into the right opening for the wiring. Then pass the cable through the nut, Connect the individual cable conductors to the relevant terminals correctly by referring to the markings on the individual conductors.
For details, refer to relevant converter IMs.

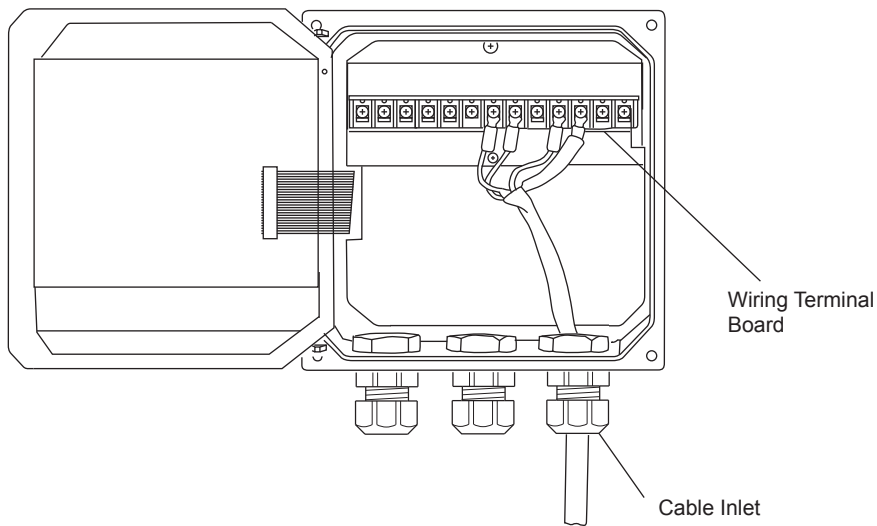

Figure 2.15 Connecting Sensor Cable to Four-wire ORP Converter

- (3) Install the cable gland in the wiring hole as follows:
 - Pass the tip of the cable gland into the opening and completely tighten the gland with the nut inside the case.
 - After tightening the gland, secure the cap properly to prevent moisture from getting into the case.
 - Caution: Do not overly tighten the cap. Otherwise, the cable may be damaged.
- (4) After completing the cable connections, close the converter cover securely, thus preventing moisture from getting into the case.

3. Maintenance on operation

3.1 Operation and Periodic Maintenance

3.1.1 Calibrating ORP Sensor Using Checking Solutions

Dirt attached to the liquid junction or sensitive parts (platinum electrodes) may have an adverse effect on electromotive force and response characteristics, so ORP sensors require periodic cleaning for good operating conditions. ORP sensors should be checked and calibrated if the following conditions are met.

- (1) Sensor checks
 - If a new ORP sensor is used or the existing sensor has been unused for an extended period of time.
 - When an ORP sensor sensitive part (platinum electrode) or a liquid junction is cleaned.
- (2) Calibration
 - If sensor electromotive force is outside the allowable ranges.
 - If the measured value by the ORP sensor is adjusted to the measured value by other sensors.

For more detailed information on the calibration procedures, see the separate Instruction Manuals "Two-wire Liquid Analyzer" (publication no. IM 12A01A03-01EN) and "Four-wire pH/ORP Converter" (publication no. IM 12B07C05-01E).

3.1.2 Cleaning Indicator Electrode and Liquid Junction

Staining of a indicator electrode or liquid junction can cause measurement errors. Therefore, if he measured solutions tend to stain the electrode, the indicator electrode and liquid junction must be cleaned periodically - depending on the degree of staining. If the ORP Sensor is installed in a holder with a cleaner, the sensor is continuously (for an ultrasonic cleaner) or intermittently (for a jet or brush cleaner) cleaned automatically.

Because of this, sensor cleaning is not usually required.

To clean the indicator electrode or liquid junction, proceed as follows:

- **Stains due to suspended Solids, Sticky Materials, Microbes or the like**

Using soft tissue paper, wipe the stains off the indicator electrode or liquid junction. In addition, clean off remaining stains by rinsing with water.
- **Stains due to Oily Materials**

Wash off stains by submerging in a neutral detergent solution in a beaker, etc, (for from several tens of minutes to several hours depending on the degree of staining).
- **Chemical Stains such as due to Metallic Adsorption**

Place the indicator electrode or liquid junction in a diluted hydrochloric acid solution (1 to 2%) for several minutes (acid washing).

3.1.3 Refilling Sensor with KCl Solution

The concentration of the KCl solution in the sensor will begin to drop when the saturated concentration cannot be maintained with the KCl solution from the liquid junction. As the concentration of the KCl solution decreases, so too does this influence the sensor's performance. To avoid this, replenish the KCl solution in the sensor before the concentration starts to decrease.

The time required for maintaining the saturated concentration of a KCl solution in a sensor is greatly influenced by the sensor's operating conditions. For example, as temperature variations in measured solutions are great, or as solution temperatures are high, so too does the amount of KCl solution drained from the liquid junction increase, thereby shortening the period of time for maintaining the saturated concentration.

In addition if the KCl solution in the sensor becomes contaminated from ions in the solution under measurement, this influences the sensor's performance. The degree of contaminated KCl solution greatly depends on the properties of the measured solution.

From the above viewpoint, we cannot precisely determine the replenishment period of KCl solution. Usually, the KCl solution in a sensor should be replenished every six months or once a year.

To replenish the KCl solution in the sensor, proceed as follows:.

- (1) Prepare a KCl solution available as an optional kit (part number: K9142UT), If it is not yet available, use instead KCl powder (about 12 g) and pure water (about 50 mL) and a clean pipette (or a 20 mL syringe) to replenish the KCl solution.

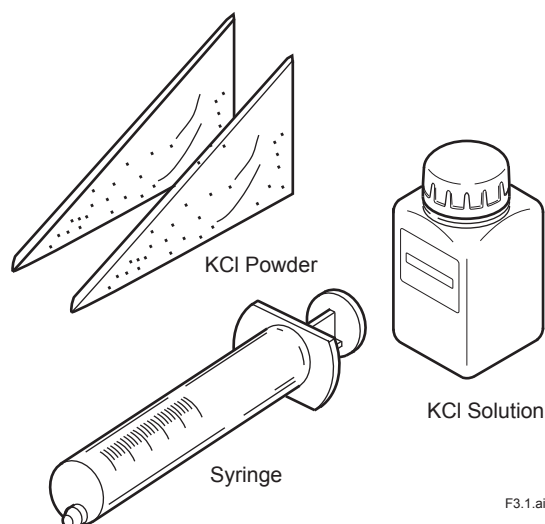

Figure 3.1 KCl Solution Replenishing Kit (Part Number: K9142UT)

- (2) Remove the sensor from its holder. Wipe off dirty areas on the sensor tip.
- (3) Remove the liquid junction from the sensor. Leave the indicator electrode mounted securely.
- (4) Drain the KCl solution in the sensor through the liquid junction mounting hole.
- (5) Wash the inside of the sensor
Pour about a 10 mL KCl solution (or pure Water) into the sensor from the liquid junction mounting hole. Shake the sensor and then drain the solution or pure water completely from the sensor.
- (6) Pour about 10 or 12 grams of powder into the sensor, Use a bag of KCl powder when using the optional KCl solution kit, Cut off the tip of the bag and follow Figure 3.2 below. If the KCl powder has hardened, break it up into pieces. Then do the above.

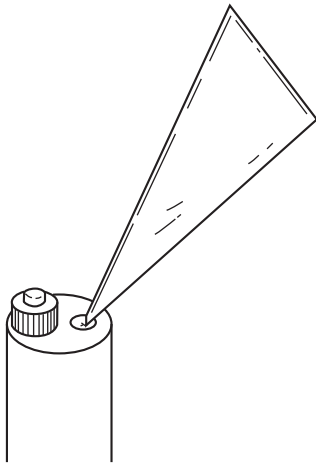

Figure 3.2 Pouring KCl Powder into Sensor

- (7) Pour the KCl solution (or pure water) into the sensor until it overflows through the junction hole. In doing this, do not leave any air pockets in the body.
- (8) Restore the liquid junction removed in Step (3) above to its original position.
Calibrate the sensor using buffer solutions.

3.2 Replacing Consumable Parts

3.2.1 Replacing Liquid Junction

Even after washing the liquid junction, if normal measurement cannot be made, replace the liquid junction.

When replacing the liquid junction, fill the sensor with KCl solution to just before the solution overflows through the liquid junction mounting hole. Use a 3.3 mol/L KCl solution (a higher concentration of KCl or KCl powder) for this application.

Check Impedance2 to judge that the liquid junction is functioning properly. Normally the Impedance2 is 50 kΩ or less in pH7 standard solution or pH4 standard solution. Read the user's manual of each converter for checking Impedance2.

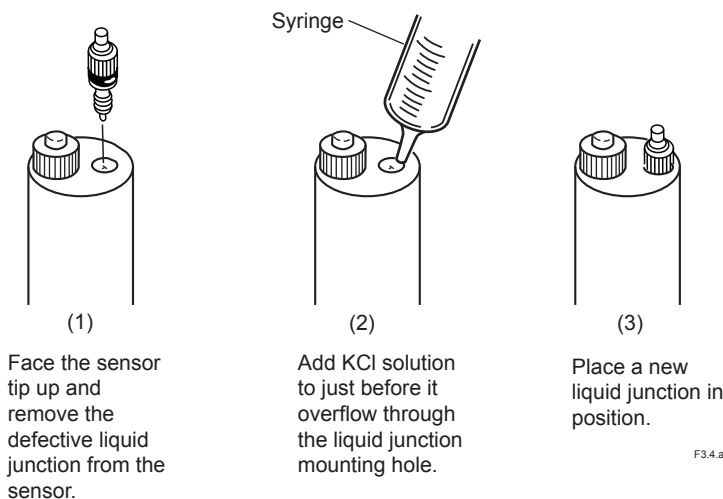
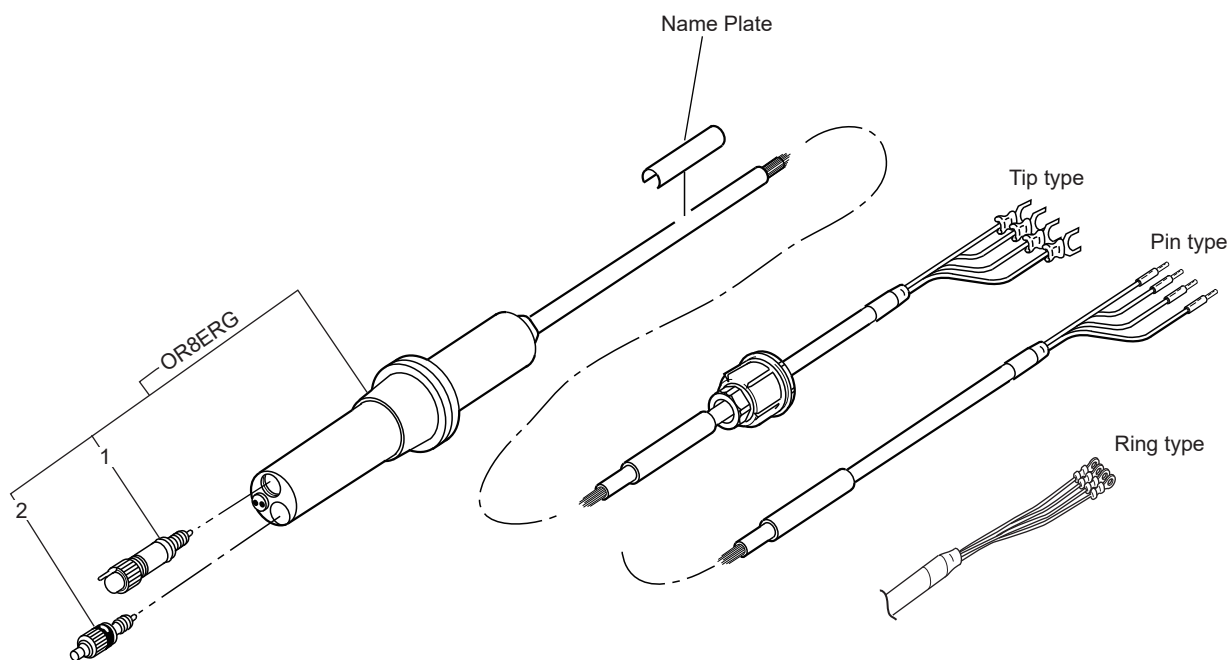

Figure 3.4 Replacing Liquid Junction

Customer Maintenance Parts List

Model OR8ERG KCI Refillable type ORP Sensor



Item	Part No.	Qty	Description
1	—	1	ORP Electrode Assembly
	K9142TS		Pt
	K9142TT		Au
	K8022GP		Pt/PF
	K8022GQ		Au/PF
2	—	1	Junction Assembly
	K9142TH		for general use
	K9319QA		for OR8ERG/PF

Revision Information

- Title : Model OR8ERG KCI Refillable type ORP Sensor
- Manual No. : IM 12C04K01-01E

Aug. 2022/10th Edition

Corrected the descriptions. (P.3-3)

Feb. 2022/9th Edition

Added option code /DG1, /MC1, /PF, and consumables (P. 1-2).
Deleted "3.2.2 Replacing O-rings for Indicator Electrode"
CMPL12C03K01-01E revised to 4th edition (Added parts for /PF).

Jul. 2021/8th Edition

Changed the description in Section "2.2.2 Installing Sensor in PH8HS Submersion Holder"

Feb. 2020/7th Edition

Added a terminal connection to -E: FLXA402 to Pin terminal (P. 1-2)

Nov. 2018/6th Edition

Added FLXA402
P i, P1-2.

Nov. 2015/5th Edition

Added FLXA202
P i, P1-2.
Unification of the material name
P1-1.

Jun. 2013/4th Edition

P 1-3, Some revision of consumables, etc.

Sep. 2011/3rd Edition Page layout changed by InDesign

P.i, Reference manual number of FLXA21 added; P.v, Some of contents corrected; P.1-2, M4 ring terminals for FLXA21 added to MS-code; P.1-3, M4 ring terminals added to external dimensions; P. 2-11, Section no. corrected (2.3.3--->2.3.4).

Apr. 2008/2nd Edition

M3 ring terminals added for PH450G, CMPL12C03K01-01E revised to 3rd edition.

Sep. 2006/1st Edition

Newly published.

Yokogawa Electric Corporation
2-9-32 Nakacho, Musashino-shi, Tokyo 180-8750, Japan

<http://www.yokogawa.com/an>
