

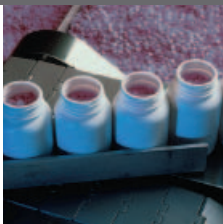

Process Mass Spectrometry in Biotechnology



Process Optimization at the Speed of Mass Spectrometry.

Field-Proven Technology with a Worldwide Installation Base

The use of online process analytical technology (PAT) has recently become a high-profile endeavor in the biotechnology industry. Yet, fermentation scientists have been using Thermo Scientific process mass spectrometers since the early 1980s to reliably monitor the composition of gas streams into and out of fermentors and bioreactors. These accurate measurements enable pre-screening for possible contamination as well as provide real-time information regarding culture respiration and the availability of nutrients. To further advance processes within the industry, a more advanced gas analysis technology platform is now available. The new Thermo Scientific Prima PRO process mass spectrometer encompasses the latest design techniques for fault-tolerant operation, ensuring high reliability for closed-loop control in harsh industrial environments.



Thermo Scientific Prima PRO Process Mass Spectrometer: The Next Generation Begins

Backed by more than 30 years of gas analysis success, the Prima PRO process mass spectrometer is a PAT tool designed to provide invaluable information during every stage of the process. From design and scale-up to full production, the next-generation gas analyzer facilitates a number of biotechnology processes and enables staff to more easily:

- Perform a fast check for contamination prior to inoculation
- Optimize transfer of inoculum from the seed tank
- Monitor metabolic activity
- Provide input to state equations, enabling timely estimates (without requiring sample withdrawal) of:
 - Viable cell mass
 - Glucose consumption rate
 - Substrate concentration
 - Alcohol production rate
 - Product inhibition
- Provide data for training neural networks and hybrid models
- Identify and quantify species that require removal for environmental compliance
- Monitor changes in kLa, enabling control of:
 - Agitation RPM
 - Sparge flow
 - Sparge oxygen concentration
- Detect and quantify drift in dissolved oxygen probes
- Monitor metabolic indicators:
 - Methanol
 - Ethanol
 - Acetone
 - Ammonia
- Identify new molecular species that might also indicate specific metabolism.

Best of all, the Prima PRO process mass spectrometer enables all of these processes without compromising sterility. It significantly increases productivity and reduces maintenance by enabling up to 60 fermentors and bioreactors to be monitored with a single analyzer.

New Model Delivers Strong ROI

- Fast (1 to 20 seconds per point) online gas analysis for accurate tracking of process dynamics
- Comprehensive and provides more data for advanced process control (APC) models
- Stable with a 30- to 90-day calibration interval (automated)
- Reliable, fault-tolerant design for availability of >99.7%
- Small footprint with no large shelter required; standard A/C sufficient
- Minimal maintenance requirements reduce operating costs

Principles of Operation

The Prima PRO process mass spectrometer is a high-performance gas analyzer based on a powerful and flexible scanning magnetic sector mass spectrometer. The platform has been designed to deliver superior analytical performance with high reliability and minimal maintenance requirements.

Mass spectrometers operate by ionizing neutral sample gas molecules, and the resulting charged particle components are separated according to their molecular weight. In most commercial gas analysis mass spectrometers, ionization is achieved by bombarding the gas sample with an electron beam produced by a hot filament. To prevent collisions, the various ions are separated in a vacuum.

Figure 1: Analyzer section—operating principles and peak profile

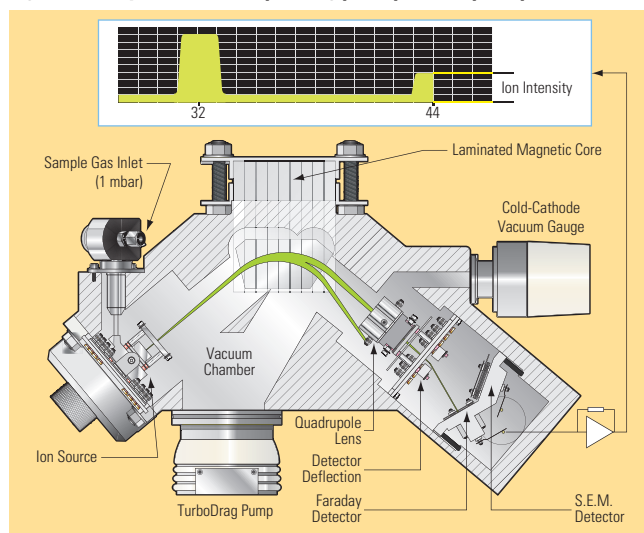

The technique chosen to separate the ions in the Prima PRO process mass spectrometer is the scanning magnetic sector where the trajectory of the ions is controlled by a variable magnetic field. Ions of interest are sequentially collected onto a single detector, enabling the analyzer to scan the whole gas sample to accurately quantify known constituents and identify unknown ones. The detector assembly combines a Faraday Cup detector that measures gas concentrations at percentage and high ppm levels and a Secondary Electron Multiplier (SEM) detector that analyzes low ppm and ppb concentrations.

The output signal from the scanning magnetic sector is a series of flat-topped peaks, each with amplitude proportional to the number of ions at each mass. Perfectly symmetrical peaks are readily achieved using the Prima PRO process mass spectrometer. Accurate intensity measurements do not rely on accurate mass peak jumping since each peak provides a large target with consistent amplitude. Since even relatively large errors in mass position will not result in any significant errors in amplitude measurement, the Prima PRO process mass spectrometer's magnetic sector is intrinsically fault-tolerant. In addition, the sector's relatively high energy ion beam (1kV typical) is not easily deflected by the inevitable local surface charges and/or insulating layers that result from contamination,

further enhancing the Prima PRO process mass spectrometer's fault-tolerant nature when compared to the very low ion energy of alternative quadrupole technology. Finally, the system's high energy ensures that extraction from the ionization region is faster than a low-energy quadrupole, resulting in reduced ion-molecule interaction and improved linearity. Long-term reproducibility to 0.01% relative can easily be achieved.

Multi-Stream Inlets

Most Prima PRO process mass spectrometers are equipped with a rapid multi-stream sampler (RMS), a highly reliable device that switches sample streams without compromising the quality of the sample presented to the analyzer. Known for rock solid reliability, the RMS has proven to switch streams six million times a year, year after year, with little or no maintenance. In fact, a single Prima PRO process mass spectrometer is capable of monitoring up to 60 fermentors and/or bioreactors. The stepper-motor driven RMS diverts one sample stream at a time to the mass spectrometer and, in turn, records the flow for each stream. The RMS can also be heated to +120°C (+248°F) and has been designed to ensure rapid response to polar species such as methanol, ethanol and ammonia.

Figure 2: Analyzer assembly with 64-port rapid multi-stream sampler that is known to switch streams six million times a year yet requires little to no maintenance.

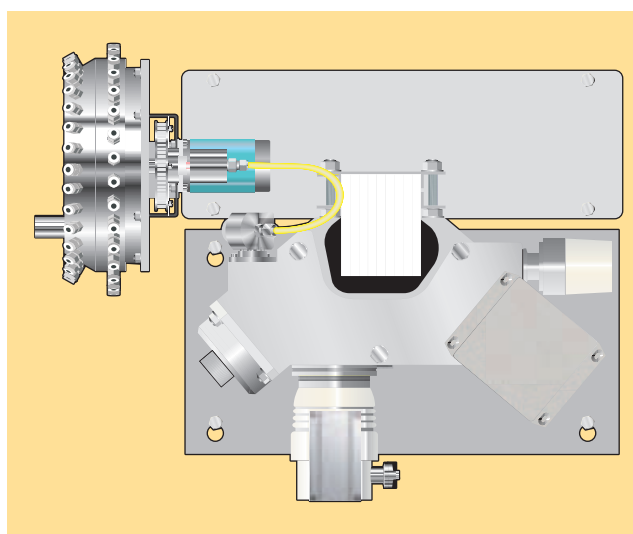

Imagine a Gas Analyzer that Can Pay You Back in Days.



Industrial Fermentation and Cell Culture

Fermentation has many important uses in industry and, strictly speaking, describes anaerobic processes. Industrial fermentation generally refers to the breakdown of organic substances and re-assembly into other substances using living cells that operate in a highly oxygenated growth medium. Microbial fermentation refers to the archaea that often thrive in extreme conditions, bacteria, fungi and protozoa. The term cell culture often refers to higher order cells such as plant, insect and mammalian. The distinction between microbial fermentation and cell culture is important from a process control perspective since hardy bacteria need less protection from process variation than mammalian cells which require tight control of temperature, pH and the shear forces produced by agitation and aeration. Control of dissolved carbon dioxide is also important in cell culture control. Based on its advanced gas analysis technology platform, the Prima PRO process mass spectrometer is designed to provide real-time information, enabling tighter process control during industrial fermentation and cell culture.



Prima PRO Process Mass Spectrometer: Versatile, Reliable and Easy-to-Maintain

The versatile Prima PRO process mass spectrometer enables optimization of a number of biotechnology processes to improve overall product quality as well as increase product yield. From bench to pilot to full-scale production, it facilitates every stage of the scale-up process and minimizes the risks associated with the complex manufacturing of:

- Bioenergy
- Industrial enzymes
- Biomaterials
- Biomass
- Food additives
- Vitamins
- Pharmaceuticals
 - Prophylactics
 - Vaccines
 - Growth factors
 - Monoclonal antibodies
 - Hormones
 - Fusion proteins
 - Cytokines
 - Antibiotics
 - Insulin
 - Thrombolytics



This modern process mass spectrometer is also engineered for ease-of-use and has minimal maintenance requirements to help increase productivity and profitability.

Simple Bioreactor Control

When compared to traditional small molecule synthesis, biological processes are very complicated. Each cell is capable of carrying out thousands of chemical reactions per second and, often times, only one reaction will result in the target molecule. How the reactions progress will be determined by a host of factors such as temperature, availability of nutrients, the amount of accumulated waste products, available oxygen, the concentration of enzymes that promote reactions and the amino acid building blocks from which proteins are made. With a simple fermentor, the growth medium is loaded following sterilization and the broth is inoculated with cells. Relatively stable sparge gas flow rates and impeller rotation rates are maintained to ensure sufficient oxygen availability throughout the medium. Once the cells start to multiply, excess heat is removed by cooling water and adjustments of pH are made using acidic and basic reagents. Dissolved oxygen (DO_2) is monitored continuously and manual assays are performed to assess cell

density and substrate composition. If DO_2 falls below a predetermined level, an additional shot of oxygen can be added by opening the oxygen valve for a brief period. In mammalian cell culture, a similar control methodology is used for dissolved carbon dioxide (DCO_2). Statistical process control (SPC) tools are used to determine if the process follows an appropriate trajectory based on data that is manually entered from the lab assays. These data are also used to determine the appropriate time to harvest. Under these circumstances, batch-to-batch variation can be significant and an order of magnitude difference is not unusual. With pharmaceutical products, if the recovered active pharmaceutical ingredient (API) falls below a certain quality standard, the entire batch must be scrapped. Clearly, the Prima PRO process mass spectrometer with its highly reliable online PAT provides lab personnel with the tools needed to considerably improve product quality and increase profitability.

Figure 3: Simple bioreactor control

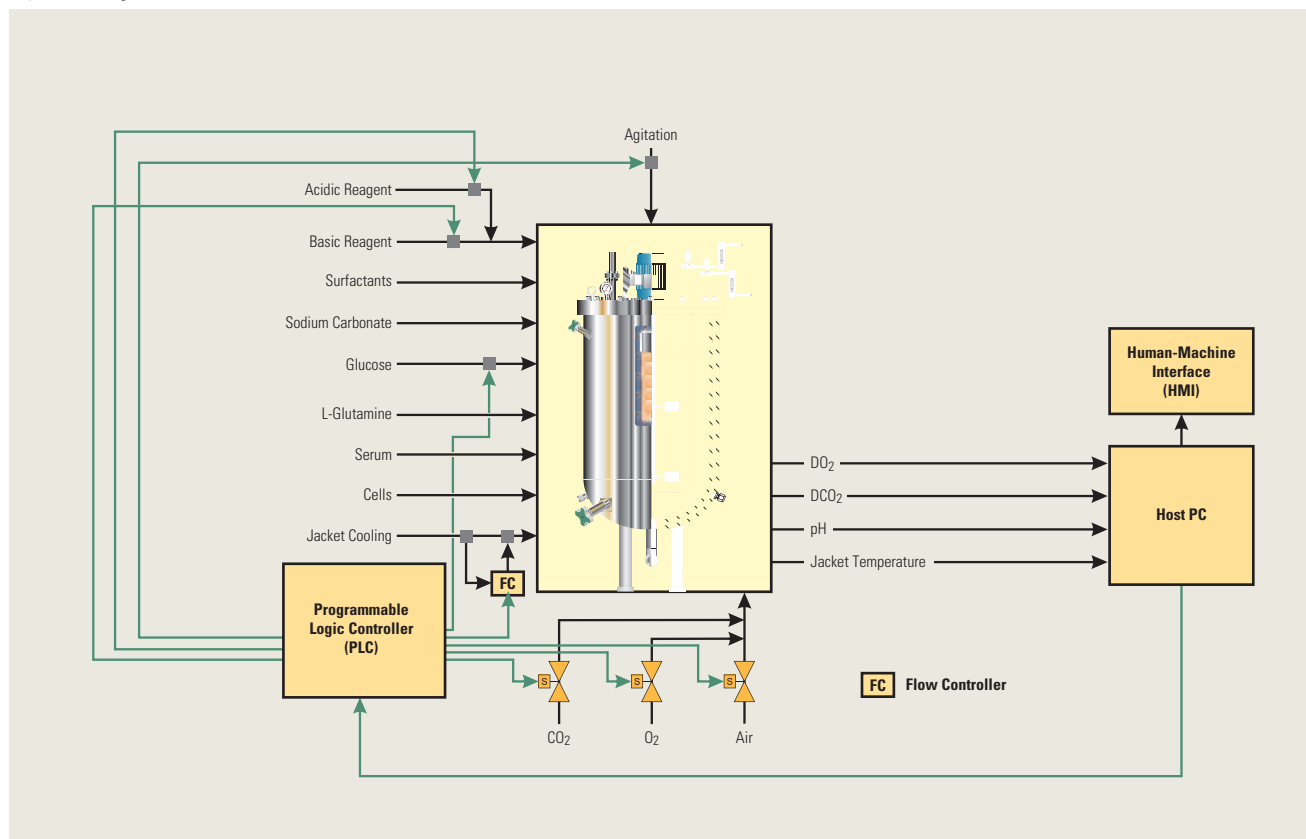

Track Batch Progress in Real Time.

Process Variables

Most bacteria used for biological production require water, carbon, nitrogen and a source of energy before they can grow and divide. As previously stated, they also have temperature, pH and gaseous requirements. The nutrients are provided in a complex growth medium that may include a number of natural products (see Fig. 4) or the media can be chemically defined for processes where natural batch-to-batch variation will present a problem. Both types of media are designed to provide the most appropriate concentration of nutrients to encourage rapid logarithmic growth until a target cell density has been achieved. At this point, the primary carbon source should be depleted to force the cells to switch to a secondary source that promotes product formation. Additional components can be included that either inhibit or induce particular metabolic pathways in order to maximize product formation and minimize accumulation of toxic byproducts.

Figure 4: Growth Media Constituents

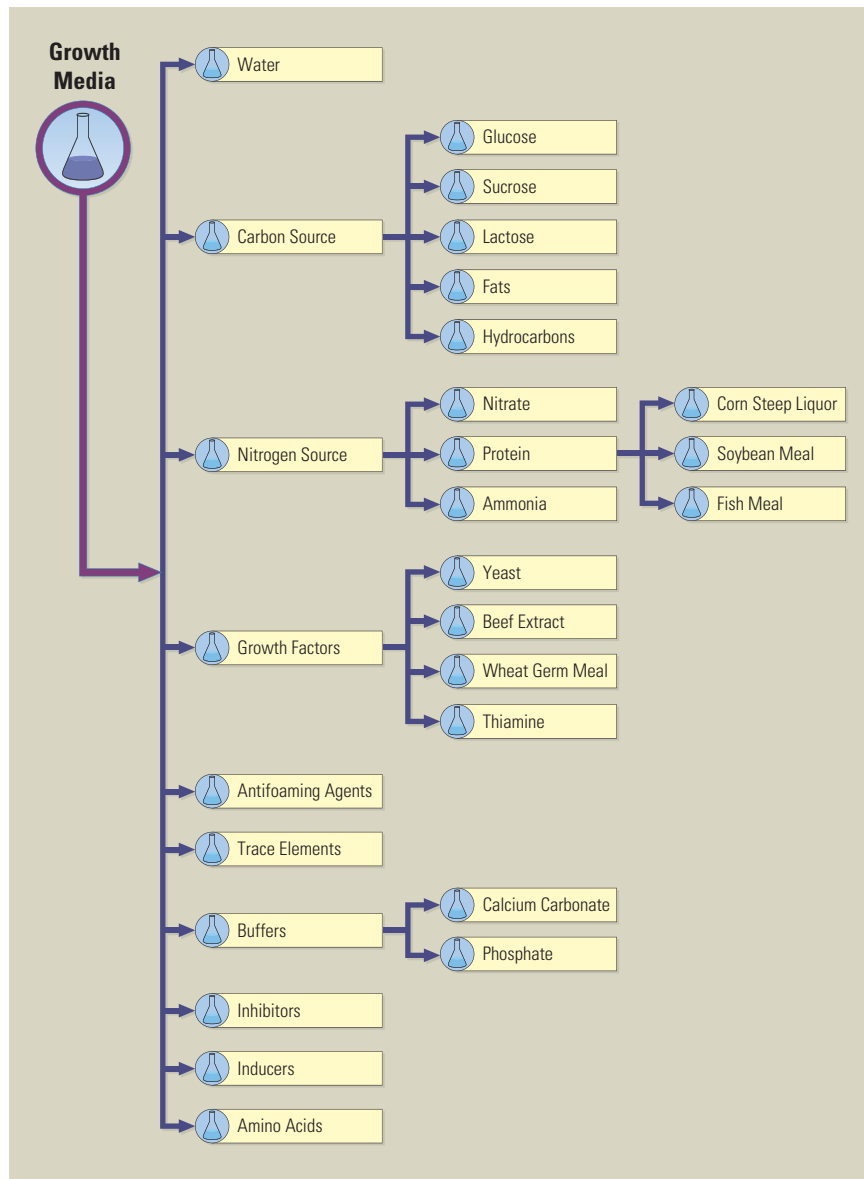

Figure 5: Autoclavable Benchtop Fermentor



Process Scale-Up

A typical scenario for process development uses multiple benchtop bioreactors or fermentors with capacities in the one to 10 liter (L) range. Various broth recipes are paired with different cell lines to determine the most robust and potent combination. Once the best candidate groupings are selected, the process is scaled up to the 200L scale (the pilot-scale) where potential control variables are fully tested for permissible range and efficacy. In addition to pH, temperature, agitation RPM, DO₂ and DCO₂, potential control variables may also include:

- Nutrient feed rates
- Back pressure
- Overlay gas composition
- Sparge composition and flow rate.

Prima PRO Process Mass Spectrometer: Real-Time Monitoring and Control

To control nutrient feeds and gas compositions in real time, it is necessary to either monitor the chemistry of the broth or the gas composition of the reactor effluent in real time. Model-based advanced process control techniques can subsequently be used to make changes to these additional control variables in response to measured changes in certain output variables. Fourier Transform Near Infrared (FT-NIR) spectroscopy is a suitable technology for measuring liquid concentrations. The best technology for making gas concentration measurements is the magnetic sector mass spectrometer, a critical component of the Prima PRO process mass spectrometer that significantly increases the analyzer's power and flexibility.

Advanced Bioreactor

Dynamic Modeling

The most frequently used methods for determining cell mass, product concentration (titer) and substrate concentration rely on the use of differential equations. These 'state equations' are interdependent and must be solved simultaneously to produce valid results based on initial conditions and real-time measurements. The initial conditions include initial mass of substrate (the primary carbon source), starting cell mass and broth volume. The real-time measurements include oxygen uptake rate (OUR), carbon dioxide evolution rate (CER), respiration quotient (RQ) and measured dissolved oxygen. The outputs from the models are typically used to track progress of each batch by comparing the results with the known trajectory of a 'Golden Batch' which provides an ideal profile for optimum product formation. This methodology ensures that limiting conditions and/or contamination can be identified and corrected as quickly as possible.

Advanced Control Techniques

There are several emerging advanced methods for implementing Model Predictive Control (MPC), including hybrid combinations of formal (deterministic) models and Artificial Neural Networks (ANN). Essentially, the ANN models fill in the gaps where first-principle analysis fails. ANNs are so called because their structure is based on layers of interconnected nodes, similar in structure to the neurons of the brain. These networks model behavior based on historical performance. The large training data sets often show that outcomes are the result of process variables falling within a range. While it might be very difficult to derive a formal explanation of the linkage, these relationships can still be used for process control. The Prima PRO process mass spectrometer enables extended analysis of the bioreactor effluent, and subsequently provides the data necessary to train these neural networks. Other mathematical modeling techniques include Principle Component Analysis (PCA) and Partial Least Squares (PLS) regression, both of which are mathematical procedures for investigating patterns and relationships in large data sets. By facilitating data compilation, the Prima PRO process mass spectrometer is a key component in successful MPC implementation.

Figure 6: Advanced bioreactor with Model Predictive Control (MPC) that is enabled by the Prima PRO process mass spectrometer

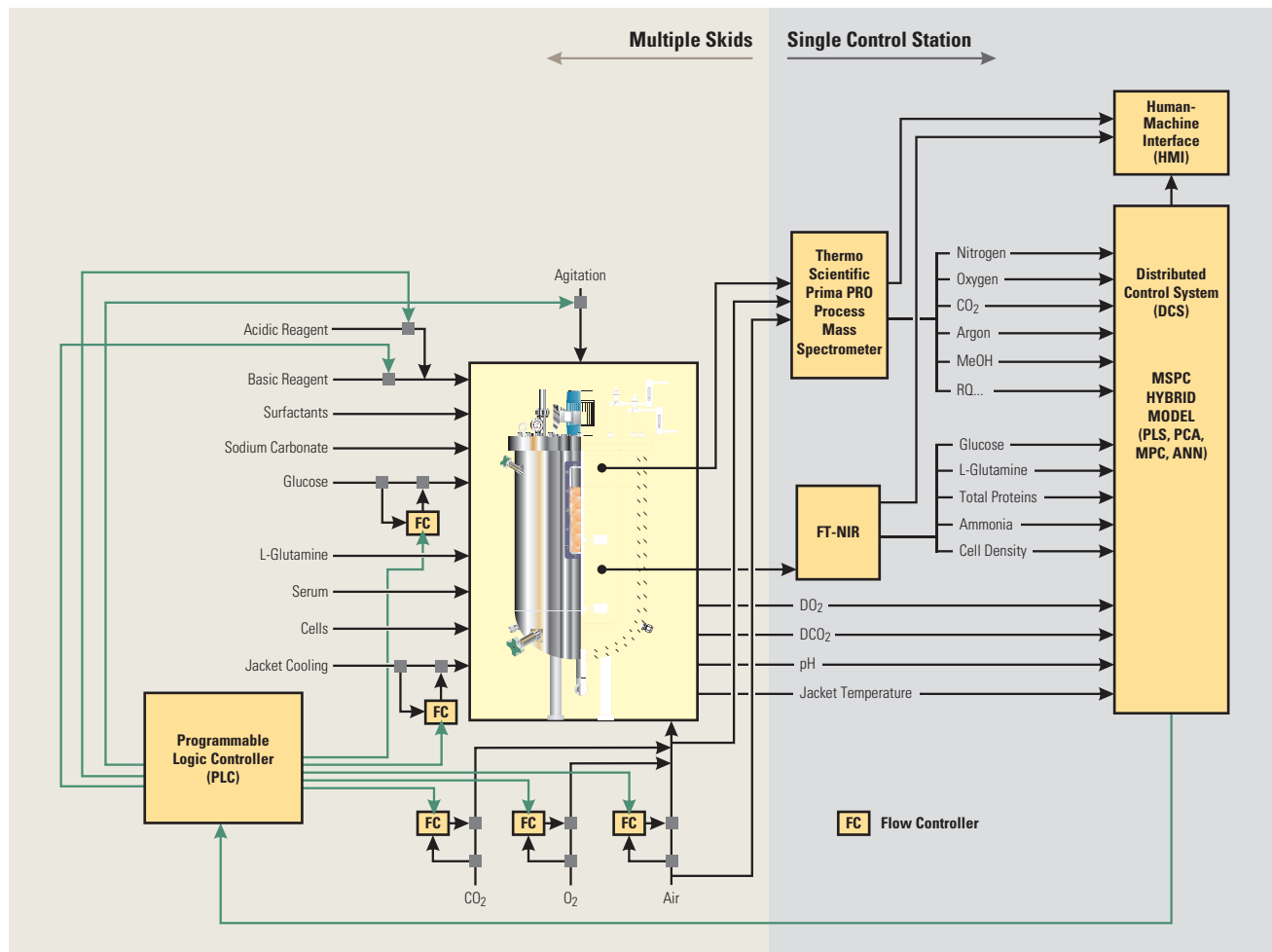

Pinpoint Contamination and Maximize Viable Cell Mass to Fuel Profits.

Advanced Bioreactor Monitoring

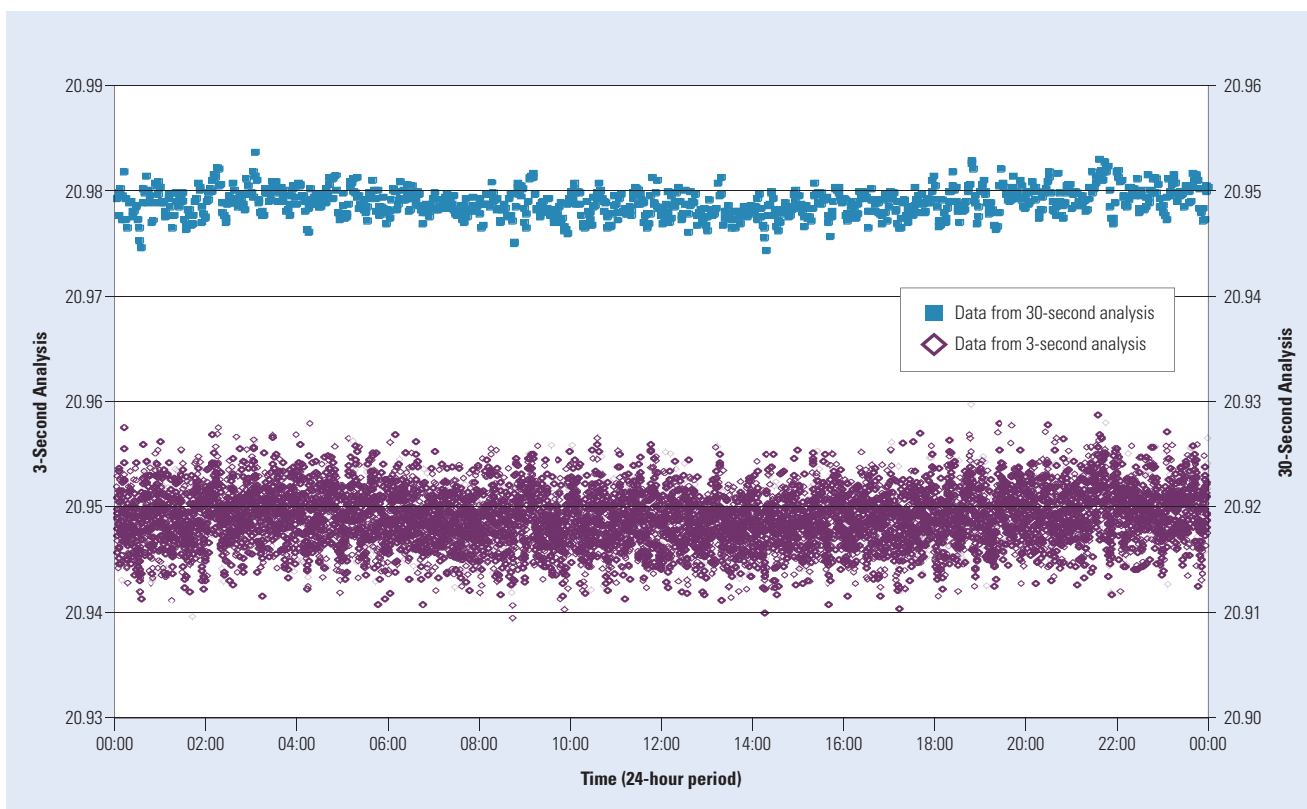

Figure 7: Oxygen stability plots per the Prima PRO process mass spectrometer

Mass Spectrometer Data Quality

The Prima PRO process mass spectrometer provides very precise measurements per the oxygen stability plots in Figure 7 and the associated statistics in Table 1. The 13 ppm standard deviation in the 30-second analysis of oxygen at 21% means that the Prima PRO process mass spectrometer can easily detect oxygen consumption below 50 ppm when the fermentor is sparged with dry air. This measurement is very useful when checking for contamination prior to inoculation since any bacterial respiration can be detected by comparing the effluent composition with that of the sparge gas. When small reductions in oxygen concentrations are correlated with similar mole percentage increases in carbon dioxide, bacterial contamination is clearly indicated.

The time spent measuring the concentration of each component in the gas stream is software-configurable, enabling the trade-off between speed and precision to be varied depending on the number of sample points and the dynamic nature of each process being monitored. A typical analysis time is five seconds for the measurement of nitrogen, oxygen, argon and carbon dioxide plus an additional three seconds for the measurement of methanol and ethanol (for example). In addition, five seconds of flushing time are added, resulting in a 10-second total analysis time per stream (or 13 seconds for the inclusion of methanol and ethanol). Since the progress is slower in mammalian cell culture than in microbial fermentation, the bioreactors can be monitored more precisely and less often than the fermentors.

Table 1: Oxygen measurement statistics per the Prima PRO process mass spectrometer

Sample Time	Data Points	% Mean	STD Absolute	STD Relative
3 seconds	9,598	20.949	0.00268	0.01281
30 seconds	960	20.949	0.00134	0.00642

Table 2: Typical Prima PRO process mass spectrometer data

Analyte	Bio1 Sparge	Bio1 Effluent
Nitrogen	78.082%	78.081%
Oxygen	20.951%	18.735%
Argon	0.939%	0.939%
CO ₂	0.028%	2.244%
Methanol		450.010 ppm
Ethanol		173.156 ppm
Acetic Acid		0.001 ppm
Acetone		0.000 ppm
H ₂ S		17.429 ppm
OUR		2.216
CER		2.216
RQ		1.000
Sample Flow	250.713 mL	180.655 mL

Oxygen Uptake Rate (OUR)

The oxygen concentration of the sparge gas and reactor effluent that is provided by the Prima PRO process mass spectrometer are sent to a process control computer. The data are combined with flow measurements and batch volume for the computation of culture oxygen uptake:

Formula for Oxygen Uptake Rate (OUR)

$$OUR = \frac{\text{sparge flow} \times (\text{sparge } O_2 - \frac{\text{effluent flow}}{\text{effluent } O_2})}{\text{liquid volume}}$$

The real-time calculation of the OUR is often used to determine the viable cell density in seed tanks, enabling determination of the appropriate time for inoculation.

Figure 8 illustrates the value of monitoring the OUR online using the Prima PRO process mass spectrometer. At first glance, the yellow line appears to simply represent cell density and the assumption would be that the batch was progressing normally. With the exception of a small change in the rate of increase, there appears to be a healthy increase in the population. Unfortunately, there is a significant fall-off in cell viability at 70 hours due to an increase in the cell death rate and dead cells are worthless. Cell viability is a state variable that requires the OUR as an input (i.e. dead cells do not breath). The OUR plot generated by the Prima PRO process mass spectrometer clearly illustrates the onset of a limiting

condition that can be quickly corrected if the cause is determined. In this case, the problem was glutamine depletion.

Formula for oxygen mass transfer rate (kLa)

$$kLa = \frac{OUR}{DO_2 @ \text{equilibrium} - DO_2 \text{ measured}}$$

The equation above indicates the efficiency with which gas phase oxygen is transferred via the liquid medium. It is an important parameter in designing the agitator and sparger and for setting the RPM and sparge flow rates as the fermentation progresses. When no mass spectrometer is available, a dynamic method is used whereby the oxygen level is varied widely while the dissolved oxygen is monitored using a DO_2 probe. Using the Prima PRO process mass spectrometer, the OUR measurement enables continuous kLa estimation. The oxygen mass transfer will change as the viscosity of the broth changes. The microbiologist needs to understand this relationship before moving to pilot scale. Once the dynamic nature of kLa is understood, deviations from the normal trajectory can be used to detect and correct DO_2 probe drift. By monitoring changes in kLa, the Prima PRO process mass spectrometer enables personnel to more easily control agitation RPM, sparge flow and sparge oxygen concentration.

Figure 8: 10-liter hybridoma plot generated by the Prima PRO process mass spectrometer

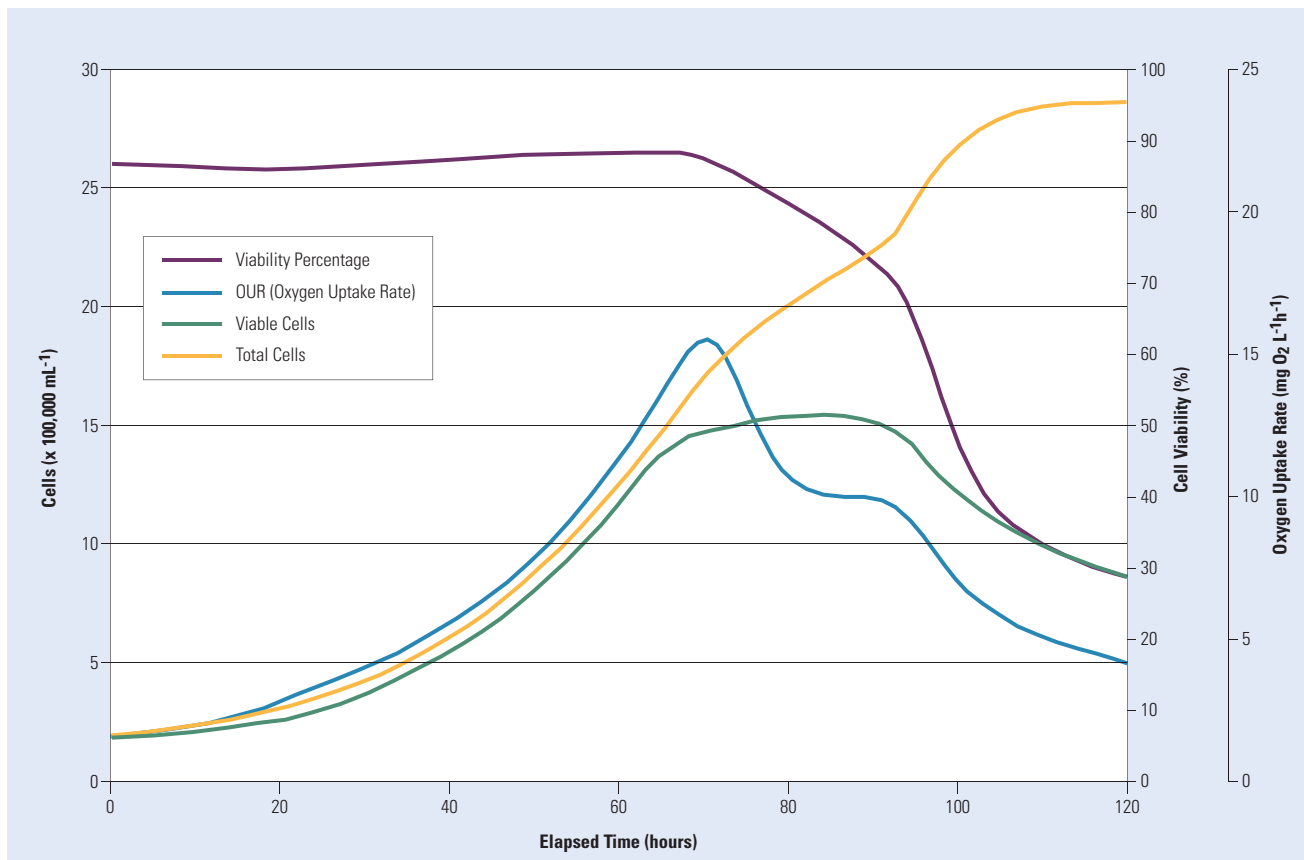

Monitor Up to 60 Fermentors and Bioreactors with a Single Analyzer.

Carbon Dioxide Evolution and Cellular Respiration

The most important variable calculated from vent gas analysis is the Respiration Quotient (RQ). It is the function of two distinct types of activity present in both fermentation and cell culture: growth and maintenance. RQ is defined as the carbon dioxide evolution rate (CER) divided by the OUR. The Prima PRO process mass spectrometer provides timely estimations of RQ that can be used to determine the current metabolic activity and potentially to enable closed-loop control of certain variables, including the Glucose Feed Rate (GFR).

The equation for fermentations that do not fix gaseous nitrogen is:

RQ for fermentations that do not fix gaseous nitrogen

$$RQ = \frac{(\text{effluent } CO_2 \times \frac{\text{sparge } N_2}{\text{effluent } N_2}) - \text{sparge } CO_2}{\text{sparge } O_2 - (\text{effluent } O_2 \times \frac{\text{sparge } N_2}{\text{effluent } N_2})}$$

RQ for fermentations that fix gaseous nitrogen

$$RQ = \frac{(\text{effluent } CO_2 \times \frac{\text{sparge } Ar}{\text{effluent } Ar}) - \text{sparge } CO_2}{\text{sparge } O_2 - (\text{effluent } O_2 \times \frac{\text{sparge } Ar}{\text{effluent } Ar})}$$

The nitrogen and argon ratios that are present correct for the partial pressure changes that occur due to saturation with water vapor and the resulting dilution of the bioreactor effluent.

An example where RQ equals one is the oxidation of glucose for energy production during the growth phase:

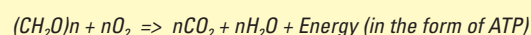

An example where RQ equals 0.7 is derived from the oxidation of stearic acid which often provides energy during the productive phase of fungal fermentations. The result comes from 18 molecules of CO_2 divided by 26 molecules of O_2 :

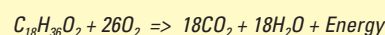

Figure 9 clearly shows the substrate depletion 50 hours into the fermentation when the metabolism switches to the fatty acid carbon source. If the OUR indicates a sufficient viable cell density, the fermentation can proceed. Otherwise, an automatic glucose addition can be initiated to prolong the growth phase.

Figure 10 indicates the resulting plot when the RQ estimation generated by the Prima PRO process mass spectrometer is used to trigger glucose additions to maximize viable cell density in a fed-batch fermentation.

Figure 9: RQ plot from 200-liter fungal fermentation

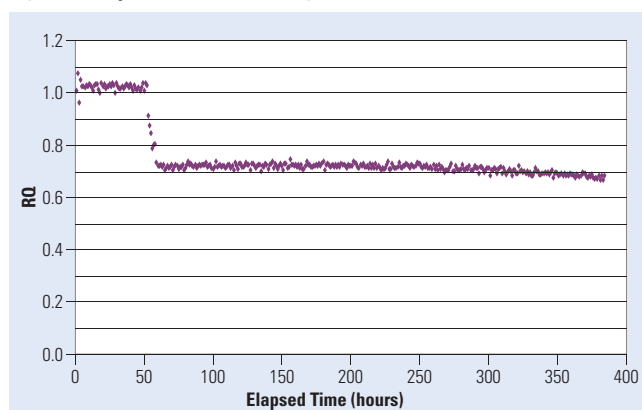
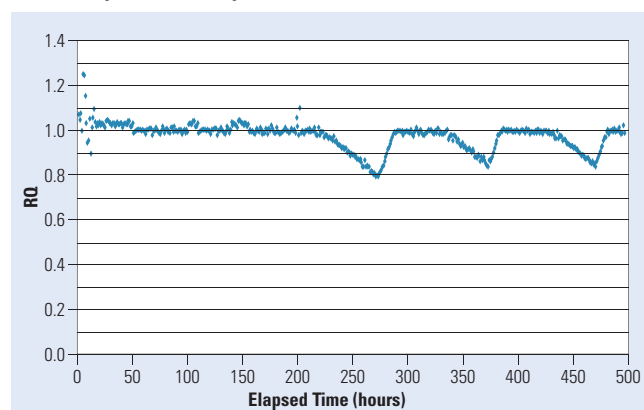

Figure 10: RQ plot from 200-liter fed batch fermentation as generated by the Prima PRO process mass spectrometer



Delivering Value during Every Stage of Product Development

The complex manufacturing processes that are inherent in biotechnology require advanced instrumentation to ensure an optimal path to the final product. Mitigating risk throughout these processes is the key to increasing profits. The Prima PRO process mass spectrometer offers the speed and precision necessary to reliably track process dynamics, enabling timely corrective action to be taken. From research and development to creation of the final product, the Prima PRO process mass spectrometer helps bring products to market faster, increase yields and enhance profits for a rapid return on investment.



Process Mass Spectrometry in Biotechnology

© 2010 Thermo Fisher Scientific Inc. All rights reserved. Results may vary under different operating conditions. Specifications, terms and pricing are subject to change. Not all products are available in all countries. Please consult your local sales representative for details. Literature Code: PI.2076.0710

14 Gormley Industrial Avenue, Unit 14	+1 (905) 888-8808
Gormley, Ontario L0H 1G0 CANADA	+1 (905) 888-8828 fax
Unit 702-715, 7/F Tower West	+86 (10) 8419-3588
Yonghe Plaza No. 28, Andingmen East Street	+86 (10) 8419-3580 fax
Beijing 100007 CHINA	
A-101, ICC Trade Tower, Senapati Bapat Road	+91 (20) 6626 7000
Pune 411016 Maharashtra INDIA	+91 (20) 6626 7001 fax
Ion Path, Road Three, Winsford	+44 (0) 1606 548700
Cheshire CW7 3GA UNITED KINGDOM	+44 (0) 1606 548711 fax
1410 Gillingham Lane	+1 (800) 437-7979
Sugar Land, TX 77478 USA	+1 (713) 272-0404
	+1 (713) 272-4573 fax

Process Instruments

www.thermoscientific.com/primapro

Thermo
SCIENTIFIC