

# General Specifications

GS 01B08E02-01EN

YS1350  
Manual Setter for SV Setting  
YS1360  
Manual Setter for MV Setting

**YS1000 Series**

Functional Enhancement

## ■ GENERAL

The YS1350 is a manual setter that allows for manually outputting setting signals to controllers and the like. The YS1360 is a manual setter that allows for manually outputting operation signals to operation terminals.

The YS1350 and YS1360 include as standard an operation mode selector switch [cascade (C) and manual (M)], status input-based operation mode selector function, and operation mode discrimination status output function.

The YS1350 and YS1360 offer high reliability thanks to Yokogawa's proprietary technology, user friendliness, and expandability. The basic type conforming to the DIN short case size contributes to space saving for mounting, and complies with standards (CE, FM, and CSA). For easy replacement of earlier models requiring the same panel cutout dimensions and depth as those of earlier models are also offered.



YS1350



YS1360

## ■ FEATURES

- A full-dot, TFT LCD  
Clear visibility of the display screen is ensured even in direct sunlight in the early morning and late afternoon. The user can freely access a desired operation screen from meter, trend, bar graph, alarm, and event displays. All parameters can be set via the front panel display.
- The parameters can all be set by operation on the front panel (no need to draw out the internal unit).
- Parameters can also be set using YSS1000 Setting Software available separately.
- Can be driven by either an AC (100 V) or DC (24 V) power supply. (Must be specified upon ordering if using a 220–240 V DC power supply.)
- Dust- and splash-proof IP54 compatible faceplate (for basic type only)
- Depth 250 mm (only for the basic type)
- No battery or capacitor is used for memory backup. No maintenance is required because batteries and backup capacitors are not used.
- CE mark (for basic types and YS100-compatible type only)
- FM Nonincendive explosion protection (optional for basic type only)
- CSA Nonincendive explosion protection (optional for basic type).
- Communication (option)  
Ethernet (Modbus/TCP) (for basic types only)  
RS485 (PC Link, Modbus, YS protocol, unavailable for YS80 internal unit-compatible type)
- Compatibility with the YS100 series  
Setting and control operations can be done with the same feel. In the case of the basic type, terminal-to-terminal pitches differ but the signal-to-terminal arrangement is almost the same. The following functions are included to ensure compatibility with the SMST.
  - Meter Display was added to the Operation Display.
  - Housing for replacement purposes (SHUP-000 separately available)

Type	Model and Suffix Codes (□ : Depending on specifications)		Analog Inputs (*1)		Analog Outputs YS1350/YS1360	Digital Out- puts	Digital Inputs
	YS1350	YS1360	1-5V	Direct Input (*2)			
Basic type	YS1350-10x	YS1360-x0x	2	-	1/2	3	2
Basic type with expandable I/O	YS1350-12x (/A □ (*1))	YS1360-x2x (/A □ (*1))	2 (1)	(1)	1/2	3	2
Compatible type for YS100	YS1350-13x	YS1360-x3x	2	-	1/2	3	2
Compatible type for YS80 internal unit							
Compatible type for EBS and I series							
Compatible type for EK and HOMAC	YS1350-14x (/A □ (*1))	YS1360-x4x (/A □ (*1))	2 (1)	(1)	1/2	3	2
Compatible type for YS80 (Compatible size for YS80 with YS100 terminal)	YS1350-15x (/A □ (*1))	YS1360-x5x (/A □ (*1))	2 (1)	(1)	1/2	3	2

\*1: The point counts shown in parenthesis are those when direct input is specified.

\*2: One of the two analog inputs can be used as direct input (option/A □ : □ = 01 to 08)

## ■ Display and Setting Functions

### ● Display functions

#### (1) Display specification

The screen is divided into Operation Display, Tuning Display, and Engineering Display groups, and functions can be set on the setting display for each function.

<b>Operation displays</b>	LOOP displays TREND displays ALARM displays METER displays FAIL display (when a failure occurs)
<b>Tuning displays</b>	Setting display Input/output data display
<b>Engineering</b>	Function settings Input specification settings Password setting Operation display settings LCD settings Communication settings

#### (2) Operation Displays

##### • Bar Graph Displays (in LOOP and DUAL displays)

<b>Scale divisions</b>	Up to 20
<b>Digits of scale markings</b>	Up to 7 digits (including decimal point and sign)
<b>Display position of scale markings</b>	At 0% and 100% positions
<b>Units</b>	Up to 7 alphanumeric characters
<b>PV bar graph resolution</b>	0.5%
<b>SV pointer resolution</b>	0.5% (only for YS1350)
<b>Alarm setting pointer resolution</b>	0.5%
<b>MV bar graph resolution</b>	1.25% (only for YS1350)
<b>PV overflow display</b>	Above 100%
<b>PV underflow display</b>	Below 0%

##### • Meter Displays (in METER displays)

<b>Scale divisions</b>	
<b>Scale graduation</b>	Automatic setting based on upper and lower scale limits (reading factor can be modified).
<b>Scale markings</b>	
<b>Reading factor</b>	
<b>Digits of scale markings</b>	Up to 4 digits (including decimal point and sign)
<b>Display position of scale markings</b>	At 0% and 100% positions
<b>Units</b>	Up to 7 alphanumeric characters
<b>PV pointer resolution</b>	0.5%
<b>SV pointer resolution</b>	0.5% (only for YS1350)
<b>Alarm setting pointer resolution</b>	0.5%
<b>MV pointer resolution</b>	1.25% (only for YS1360)

##### • Tag Number and Digital Value Displays

<b>Display characters for tag numbers</b>	Alphanumeric characters
<b>Display digits of tag numbers</b>	Up to 12
<b>Display digits of PV and SV digital indications</b>	Up to 7 (including decimal point and sign)
<b>Display digits of MV digital indications</b>	Up to 6 (including decimal point and sign)

##### • Trend display specification

###### Trend display types

<b>Trend 1 Display</b>	PV1 and SV1 trends can be displayed and hidden. PV1 and SV1 scaling can be displayed.
<b>Trend 3 Display</b>	Four arbitrary values for PV1, SV1, PV2, SV2, X1, and X2 can be selected and displayed on a single display. PV scaling can be displayed.

###### Trend display time span

<b>Trend display time span</b>	1.5 minutes, 7.5 minutes, 15 minutes, 45 minutes, 1.5 hours, 7.5 hours, 15 hours, and 45 hours
--------------------------------	--

##### • Event display specification

<b>Function</b>	When an event occurs, a popup window appears on Operation Display. Preset messages appear in the popup window.
<b>Cancel and redisplay</b>	The event display can be closed by pressing the SHIFT key for three seconds and the messages can be redisplayed in the ALARM display.
<b>Number of settable events</b>	Up to 5
<b>Setting software (available separately)</b>	The YSS1000 (Setting software for the YS1000) is used. Display details and event flags are set with the YSS1000's event display function.

##### Display during Failure

The display is automatically switched to the FAIL display upon a failure.

Refer to the functional specification.

## • Display section names

### (1) Front panel section names

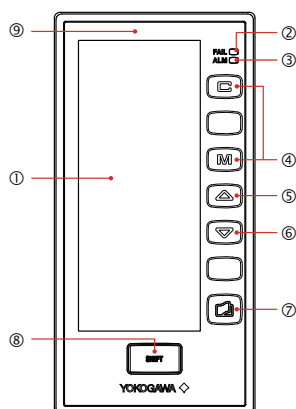

YS1350 front panel

YS1350	
1	LCD display unit (color LCD): 120 x 320 dots *1
2	FAIL lamp (LED: red)
3	ALM lamp (LED: yellow)
4	C mode key (LED: green), M mode key (LED: yellow)
5	SV increase key
6	SV decrease key
7	Page key
8	SHIFT key
9	Tag label (recommended placement position)

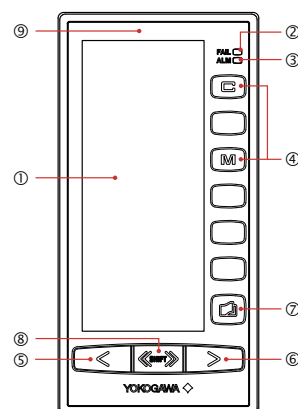

YS1360 front panel

YS1360	
1	LCD display unit (color LCD): 120 x 320 dots *1
2	FAIL lamp (LED: red)
3	ALM lamp (LED: yellow)
4	C mode key (LED: green), M mode key (LED: yellow)
5	MV decrease key
6	MV increase key
7	Page key
8	Fast-change key/SHIFT key
9	Tag label (recommended placement position)

\*1: The backlight brightness can be adjusted, and the backlight can be turned off.

### (2) Swing-up internal panel section names

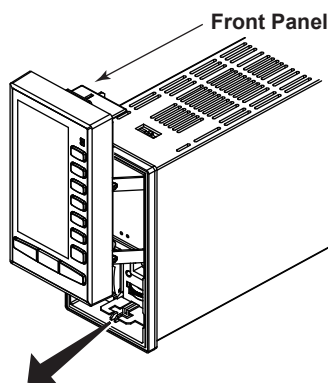
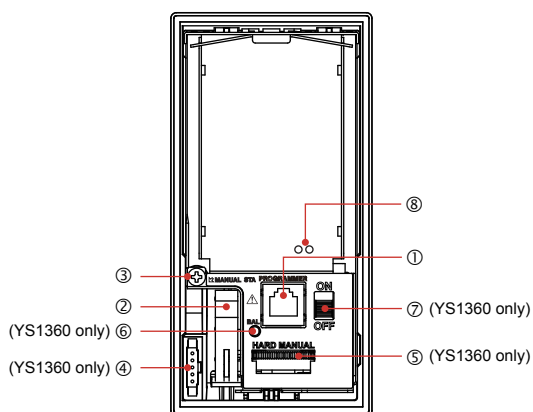

#### • Control output backup (For suffix code -1xx)

(For YS1360 only)  
The hard manual wheel behind the front panel enables manual operations. Output balancing before switching to/from hard manual is possible.  
Note: Connecting the YS110 standby manual station enables the internal unit to be replaced without interrupting the 4 to 20 mA DC control output (Y1). (Replacement of the internal unit, however, should be performed by a Yokogawa authorized service person.)

Item	Name	Remark
1	Connector for PC connection (PROGRAMMER)	A communication cable connector to download and upload parameters set with YSS1000 Setting Software
2	Internal unit's release bar	Do not draw out the internal unit. If you need to draw out the internal unit, ask our sales representative or service office.
3	Internal unit's fixing screws	
4	Connector for the YS110 Standby Manual Station	Can be used only for YS1360.
5	Hard manual operation wheel	Can be used only for YS1360. An operation wheel for output manipulation.
6	MV balance lamp	Can be used only for YS1360. Lights up when the manipulated output value and the hard manual output value match.
7	Hard manual selector switch	Can be used only for YS1360. Used to switch over the output (MV) to the level set by the hard manual operation wheel.
8	LED and switch for repair	Contact us for repair.

## ■ Functional Specification

### ● Alarm function

Name	Setting range	Remark
High limit alarm setpoint for PV	-6.3 to 106.3%	Set in engineering units
Low limit alarm setpoint for PV	-6.3 to 106.3%	
Alarm hysteresis	0.1 to 20.0%	

- Alarm output: 2 points
- Contact status during alarm: Close or open as selected by the user.
- Contact status during power failure: Open.

Name	Service	Indication When Alarm Setpoint is Set or When Alarm Has Occurred	Remark
Alarm setting pointer display	High limit alarm setpoint for PV	Yellow pointer	LOOP Display
	Low limit alarm setpoint for PV	Yellow pointer	METER Display
Alarm Indications	ALM lamp	Lights up in yellow	—
	Alarm occurrence indication	Alarm indication on LOOP display	—
	Alarm name display	Display on ALARM	—
	Tag number inversion display	Inversion and alternating display of tag numbers in all displays	Enabled and disabled by a parameter.
	Active display	Change of PV bar and its background colors	Alarm type to cause the active display is to be set by a parameter.

### ● Input signal computation function

	Name	Setting Range
Square root computation	PV square root computation	OFF: square root computation disabled ON: square root computation enabled
	PV square root computation low signal cut off point setting value	0.0 to 100.0%

### ● Output signal computation function

	Name	Setting Range
Output limiter function for MV	High limit output limiter	-6.3 to 106.3%
	Low limit output limiter	-6.3 to 106.3%

### ● Input and output computation period

100 ms

### ● Power failure and power return operation

Operation starts under the conditions of start mode set with the parameters.

Parameters are stored in the nonvolatile memory.

- Return mode

Select from the following return modes.

Start Mode	Duration of Failure	
	Less than approx. 2 s	Approx. 2 s or longer
AUT mode	Hot start	Hot start
M-COLD mode	Hot start	M-cold start
C-COLD mode	Hot start	C-cold start
COLD mode	Hot start	Cold start

### ■ Response to Power Recovery

	Start Mode (START)			
	HOT start	M-COLD start	C-COLD start	COLD start
C and M status	Remains the same as before power failure..	M mode	C mode	Remains the same as before power failure.
Manipulated output (MV) (YS1360)	Remains the same as before power failure.	-6.3%		
Setting value (SV) (YS1350)	Remains the same as before power failure.			
Parameter	Remains the same as before power failure.			
First-order lag computation	Continuously performed.	Initialized		
Process alarm and system alarm	Continues without change		OFF	
Analog output terminal Y1 (YS1360)	Continues without change		-20%	
Analog output terminal Y2	Continues without change		-6.3%	
DO01 to DO02, DO04	Continues without change		OFF	

### ● Self-diagnosis function

#### (1) FAIL

Diagnosis Content
Clock stop
Main CPU abnormal
Display CPU abnormal
A/D conversion unit abnormal
RAM abnormal
System ROM abnormal
Nonvolatile memory abnormal

When a failure occurs:

FAIL lamp lights up.

FAIL contact output open

(Open when a power failure occurs)

#### (2) Alarm

Diagnosis Content
System alarm
Process alarm

When an alarm is generated:

ALM lamp lights up.

The alarm cause is displayed on the screen.

Active display (only when the function is set to ON)

= When a process alarm is generated, the color of the PV bar on LOOP Display changes.

Tag blinking display (only when the function is set to ON)

= When an alarm lamp lights up, the color of the tag is changed and blinking alternately.

### ● Screen display when a failure occurs

When a failure occurs, the screen changes to FAIL Display.

When the main CPU fails, FAIL Display is displayed using the display CPU, and output can also be performed in MAN mode.

When the display CPU fails, FAIL Display is displayed using the main CPU, and output can also be performed in MAN mode.

When the display CPU fails, FAIL Display is displayed using the main CPU, and output can also be performed in MAN mode.

### ● Security

Password-based parameter protection function

## ■ Hardware Specification

### ● Input and output signal specification

#### Analog input signal

	Specification
1 to 5 VDC	2 points, PV input and cascade input
Input resistance	1 MΩ
Direct input (*1) (option)	One of the above 2 points (PV input) possible

\*1: Any one of mV, thermocouple, resistance temperature detector, potentiometer, 2-wire transmitter, input isolator, or frequency input. For the details of direct input, refer to "Direct Input Specification."

#### Analog output signal

	YS1350	YS1360
4 to 20 mA	None	1 point
Load resistance	None	0 to 750 Ω
1 to 5 VDC	1 point	1 point
Load resistance	2 kΩ or more	2kΩ or more

#### Digital input

	Specification
Digital input	2 points (operation mode switching input, LCD backlight auto-off input)

Input signal	ON	OFF
In case of no-voltage contact (*2) (*3)	Close Resistance 200 Ω or less	Open Resistance 100 kΩ or more
In case of voltage contact (*2)	Low Input voltage -0.5 to 1 VDC	High Input voltage +4.5 to 30VDC

\*2: Input contact rating: 5VDC, 20 mA or more Minimum pulse width: 120 ms

\*3: The no-voltage contact and voltage contact share the same terminal.

#### Digital output

	Specification
Digital output	3 points (C/M status output, high limit alarm output, low limit alarm output)
Transistor contact	Rating: 30 V DC, 200mA (resistance load)
FAIL output (*4)	1 point
Transistor contacts	Rating: 30 V DC, 200 mA (resistance load)

\*4: FAIL contact output is in the off state when the power is OFF and a failure occurs. (In normal time: on state) Operation is a NC operation.

### ● Transmitter power supply

	Specification
Output voltage	25 to 25.5 VDC
Load	30 mA or less (60 mA or less when direct input is not used)
Short-circuit protection	80 mA ±10 mA
Other	The computation circuit is not affected by a short circuit. Not isolated from the computation circuit. 1 to 5 V conversion resistance (250 Ω) shall be supplied externally.

### ● Isolation of signals from each other

	Specification
Analog input and output signal	Not isolated from the computation circuit. Signals are not isolated from each other. The negative wire is shared. Isolated from other input and output signals.
Direct input	Except for a 2-wire transmitter (not isolated), the input signal and computation circuit are isolated. Isolated from the power supply circuit, and other input and output signals.
Digital input and output signal	Isolated from the computation circuit. Sig- nals are also isolated from each other. Iso- lated from other input and output signals.
FAIL signal	
Communication	Isolated from the computation circuit. Iso- lated from other input and output signals.
Power supply	
Grounding	

### ● Reference performance

#### Reference operating conditions

Ambient temperature: 23°C ±2°C, relative humidity: 50% ±10%

However, the power supply voltage shall be as follows.

24 VDC ±10% or 100 VAC ±10%, 50/60 Hz

135 VDC ±10% or 220 VAC ±10%, 50/60 Hz

Item	Specification
Input and output con- version accuracy rating	
1 to 5 V input signal	±0.1% of span
Direct input	±0.5% or ±(2 x   direct input card accuracy   + 0.1%)
Analog voltage output	±0.1% of span
Analog current output	±0.2% of span
Allowable input voltage (*1)	
1 to 5 V signal	±30 VDC
Direct input signal (mV, TC)	-0.5 to 4 VDC
Direct input signal (distributor)	+40 mA DC
Warm-up time	1 minute (time required to meet the tolerance after the power is turned on), 3 minutes in the case of direct input.
Input resistance	1MΩ (1 to 5 V input)
Current consumption and power consump- tion	100 VAC and 24 VDC common power supply 750 mA (20 to 132 VDC) 30 VA (80 to 138 VAC) 220 VAC power supply 110 mA (120 to 340 VDC) 30 VA (138 to 264 VAC)
Insulation resistance	100 MΩ or more (at DC 500 V) between input and output terminal and ground ter- minal, and between power supply terminal and ground terminal
Withstanding voltage	Between input/ output terminal and ground terminal 1000 VAC for one minute (for suffix codes -x0x or -x2x) 500 VAC for one minute (for suffix codes -x3x, -x4x, -x5x) Between power sup- ply terminal (L, N) and (all I/O terminal and ground terminal) 3000 VAC for one minute (for suffix codes -x0x or -x2x) Between power supply terminal (L,N) and ground terminal 1500 VAC for one minute
LCD display unit replacement cycle	8 years

\*1: Measurement classification in accordance with IEC/EN 61010-1, IEC/EN 61010-2-201, IEC/EN 61010-2-030, and CAN/CSA-C22.2 No.61010-1, CAN/CSA-C22.2 No. 61010-2-030: O (other)

#### Regarding the LCD

A small number of missing or steady-on LCD pixels and minor variations in brightness uniformity is a normal display characteristic and not a malfunction.

---

**• Influence of operating conditions**

Item	Specification
Influence of changes in power supply	Accuracy  (in the range of power supply rating)
Influence of input lead resistance	0.13% (per 1 k $\Omega$ )
Influence of load resistance	Accuracy /5 2 k $\Omega$ to $\infty$ , 1 to 5 V output 0 to 750 $\Omega$ , 4 to 20 mA
Common mode noise rejection ratio	83 dB (1 to 5 V input) 50/60 Hz
Series mode noise rejection ratio	46 dB (1 to 5 V input) 50/60 Hz
Influence of magnetic field	Accuracy /5 (400 A/m, 50/60 Hz or DC)
Influence of ambient temperature	Accuracy  (per 10°C in the range of 0 to 50°C)
Influence of ambient humidity	Accuracy  (50 to 93% RH, 40°C)

## ■ Communication Signal Specification

Item	Programmer Communication (Used for YSS1000)	RS-485 Communication
Electrical specification	RS-232C compliant	EIA RS-485 compliant
Transmission control methods	Asynchronous, no procedure, half-duplex	Asynchronous, no procedure, half-duplex
Baud rate	-	1200, 2400, 4800, 9600, 19200, 38400 bps
Protocol	Dedicated protocol	PC link PC link with SUM Modbus ASCII Modbus RTU (Slave) YS protocol
Connection	Dedicated front panel connector	Back panel screw terminal (5 terminals and 1 ground terminal)
Number of connection modules	1 module	Up to 31 modules/port
Applicable cable	Dedicated cable A1053UR(USB-RS232C conversion cable)	Shielded twisted pair wire Wire size: 0.5 to 1.25 mm <sup>2</sup> (AWG No. 20 to 16)
Cable length	About 2.7 m	Up to 1200 m (1.25 mm <sup>2</sup> )

Item	DCS-LCS Communication	Ethernet Communication
Electrical specification	Yokogawa's proprietary one	IEEE802.3 compliant-10BASE-T/100BASE-TX
Transmission control methods	Back panel screw terminal (2 terminals)	CSMA/CD
Baud rate	-	10 Mbps, 100 Mbps
Protocol	-	Modbus/TCP (Server)
Connection	-	Back panel RJ45 connector
Number of connection modules	8 modules/LCS card 4 modules/SCIU card	Up to 4-tier cascade stack(10BASE-T) Up to 2-tier stack(100BASE-TX) (*1) Number of connections: 2 Maximum number of transactions: 1 (*3)
Applicable cable	Dedicated shielded twisted pair wire (Model: SCCD)	10BASE-T/100BASE-TX cable
Cable length	Up to 100 m	100 m (*2)

\*1: Number of cascade connected hubs

\*2: Maximum segment length  
(length between hub and YS1350/YS1360)

\*3: Per a connection

### ● Communication functions

Communication with the host systems

Communication with host systems such as Yokogawa's DCS (CENTUM) or Yokogawa's PLC (FA-MA3) is possible.

Destination	Link device in host system	YS1350/1360 communication functions	
		Option	Protocol
CENTUM CS3000 or VP	ALR121 (direct communication)	RS-485 communication ((A31))	YS protocol
FA-M3	UT link module		PC link
PLC or PC from other vendors	Device with RS-485 communication functions	Ethernet communication ((A34))	Modbus RTU/ASCII (Slave)
	Device with Ethernet communication functions		Modbus/TCP (Server)

#### ■ Communication items

Measured values can be read out and configuration parameters can be read out and written. Data setting can be enabled and disabled through the use of communication.

#### ■ Computer modes:

In addition to the previously mentioned normal operation modes, there are two operation modes for control by an host system.

In DDC mode, the control output MV is directly manipulated by the host system (for YS1360 only).

In SPC mode, the control setpoint SV is manipulated by the host system (for YS1350 only).

#### ■ Backup mode after communication fault:

The mode into which the controller should fall when communication with the host system has continuously been lost for a preset time period, the M mode is activated.

## Direct Input Specification

Item	mV input	Thermocouple Input
Optional code	/A01	/A02
Input signal	DC potential difference -50 to +150 mV	JIS and ANSI standards, thermocouple types K, T, J, E, B, R, S IEC and ANSI standards, type N
Measurement range span	10 to 100 mVDC	10 to 63 mV (thermoelectric power equivalent)
Measurement range zero elevation	Within the smaller value out of either 3 times the span or $\pm 50$ mV	Within the smaller value out of either 3 times the span or $\pm 25$ mV
Measurement range	Can be changed on Engineering Display.	
Input resistance	1 M $\Omega$ (3 k $\Omega$ in the event of a power failure)	
External input resistance	500 $\Omega$ or less	
Allowable input voltage and current	-0.5 to 4 VDC	
Input linearization	No	Yes
1 to 5 V output conversion accuracy rating	Within $\pm 0.2\%$ of span	The larger value out of either $\pm 0.2\%$ of span or input equivalent $\pm 20$ $\mu$ V
Reference junction compensation error	-	Within $\pm 1^\circ\text{C}$ (*1)

\*1: Reference junction temperature compensation is not performed for type B.  
With the exception of type B, when the measured temperature is less than  $0^\circ\text{C}$ , the above value is to be multiplied by the following factor (K).  
K = (thermoelectric power per  $1^\circ\text{C}$  around  $0^\circ\text{C}$ ) / (thermoelectric power per  $1^\circ\text{C}$  for the measured temperature)

Item	Resistance Temperature Detector Input	Potentiometer Input
Optional code	/A03	/A04
Input signal	Pt 100 (IPTS-68:JIS'89), JPt100 (JIS'89) Pt100 (ITS-90: JIS'97), Pt50 (JIS'81) 3-wire Measurement current: 1mA	Potentiometer, 3-wire
Measurement range span	10 to $650^\circ\text{C}$ (Pt100) 10 to $500^\circ\text{C}$ (JPt100)	Total resistance: 100 to 2000 $\Omega$ Span: 80 to 2000 $\Omega$
Measurement range zero elevation	Within 5 times the span	Within 50% of total resistance
Measurement range	Can be changed on Engineering Display.	
External input resistance	10 $\Omega$ or less per wire (*2)	10 $\Omega$ or less per wire
Input linearization	Yes	No
1 to 5 V output conversion accuracy rating	The larger value out of either $\pm 0.2\%$ of span or $\pm 0.2^\circ\text{C}$	Within $\pm 0.2\%$ of span

\*2: The value shall be equal or less than the smaller value out of 10  $\Omega$  per wire or (measurement temperature span)  $\times$  0.4  $\Omega$ .

Note: There is no difference between the latest and the previous temperature tables as far as applying them to the YEW SERIES.

- TC: Latest version; IEC60584-1: 2013/JIS C1602:2015  
Previous version; IEC60584-1: 1995/JIS C1602:1995
- RTD Latest version; IEC60751- 2008/JIS C1604:2013  
Previous version; IEC751- 1995/JIS C1604:1997

Item	Input Isolator	2-wire Transmitter Input and 2-wire Transmitter Input (Input Not Isolated)
Optional code	/A05	/A06, /A07
Input signal	1 to 5 VDC	4 to 20 mADC signal from the 2-wire transmitter (power is supplied to the transmitter)
Input resistance	1 M $\Omega$ (100 k $\Omega$ in the event of a power failure)	250 $\Omega$
External input resistance	-	RL = within (20-minimum transmitter operating voltage)/(0.02 A ( $\Omega$ ))
Allowable input voltage and current	$\pm 30$ VDC	40 mADC
Input linearization	No	No
1 to 5 V output conversion accuracy rating	Within 0.2% of span	

Item	Frequency Input
Optional code	/A08
Input signal	2-wire: contact, voltage pulse, current pulse (power can also be supplied to the transmitter) 3-wire: power supply type voltage pulse
Input frequency	0 to 10 kHz (0 to 10 Hz when the input filter is set to ON.)
100% frequency	0.1 to 10 kHz (0.1 to 10 Hz when the input filter is set to ON.)
Zero elevation	0 to 50% can be set for 100% input frequency.
Measurement range	Can be changed on Engineering Display
Low level input cut off point	Setting range: 0.01 Hz (and 1% of maximum frequency) to 100% input frequency.
Minimum input pulse width	ON: 60 $\mu$ s OFF: 60 $\mu$ s (input frequency 0 to 6 kHz) ON: 30 $\mu$ s OFF: 30 $\mu$ s (input frequency 6 to 10 kHz)
Input signal level	Contact input: relay contact, transistor contact Open and close detection level, open: 100 k $\Omega$ or more, close: 200 $\Omega$ or less Contact capacity: 15 VDC, 15 mA or more Voltage and current pulse input: low level: -1 to +8 V, high level: +3 to +24 V Pulse wave high value: 3 V or more (input frequency 0 to 6 kHz), 5 V or more (input frequency 6 to 10 kHz)
Internal load resistance (for current pulse)	Selectable from 200 $\Omega$ , 500 $\Omega$ , and 1 k $\Omega$ . This item is to be specified at the time of ordering.
Input filter	Selectable whether to add a 10 ms filter (for no-voltage contact). This item is to be specified at the time of ordering.
Power supply for transmitter	Selectable from 12 VDC/30 mA or 24 VDC/30 mA. This item is to be specified at the time of ordering.
1 to 5 V output conversion accuracy rating	Within 0.2% of span



## ■ Operating Conditions, Transport, and Storage Conditions

### ● Normal operating conditions, transport and storage conditions

Item	Normal Operation	Transport and Storage
Ambient temperature	0 to 50°C	-20 to 60°C
Ambient humidity	5 to 90% RH (no condensation)	5 to 95% RH (no condensation)
Power supply voltage (AC) (*1)	80 to 138 VAC (100 VAC and 24 VDC power supply) 138 to 264 VAC (220 VAC power supply)	-
Power supply frequency (AC)	±3 Hz	-
Power supply voltage (DC) (*1)	20 to 132 VDC (100 VAC and 24 VDC power supply) 120 to 340 VDC (220 VAC power supply)	-
Continuous vibration	5 to 14 Hz, amplitude: 0.625 mm or less, 14 to 150 Hz, 4.9 m/s <sup>2</sup> or less, orthogonal three-directional, with 2 hours each	
Short-time vibration	14.7 m/s <sup>2</sup> , 15 s or less	
Shock	49 m/s <sup>2</sup> (5G) or less 11 ms or less	
Package drop	Within 1 m	
Magnetic field	400 A/m or less	
Hazardous gas	There shall be no corrosive gas in the location.	
Installation altitude	2000 m above the sea or less	
Atmospheric pressure	86k to 106 kPa	

\*1: The safety standard and FM/CSA non-incentive standard compliance conditions apply to the following power supply ratings.

For AC (100 V) and DC (24 V DC) dual power drive models:

- 24 to 120 V DC (±10%), no polarity, 750 mA MAX
- 100 to 120 V AC (±10%), 50/60 Hz (±3 Hz), 30 VA MAX

For 220 V AC power drive models:

- 135 to 190 V DC (±10%), no polarity, 110 mA MAX
- 220 to 240 V AC (±10%), 50/60 Hz (±3 Hz), 30 VA MAX

## ■ Safety Standard

Item	Content	Remark
General safety compliance standard	Compliant with IEC/EN 61010-1, IEC/EN 61010-2-201, IEC/EN 61010-2-030 Overvoltage category: II Pollution Degree: 2 Measurement category: O (other) Rated voltage to earth of measuring circuit terminal: 33 V ACrms (50/60 Hz) or 70 V DC Compliant with CAN/CSA-C22.2 NO. 61010-1 and CAN/CSA-C22.2 NO. 61010-2-030 Overvoltage category: II Pollution Degree: 2 Measurement category: O (other)	Only for the models with suffix code -x0x or -x2x.  For suffix code: -x0x and /CSA option, compliant with CSA.
EMC compliance standard	EN 61326 Class A EN 55011 Class A Group 1 EN 61000-3-2 EN 61000-3-3 Note: The instrument continues to operate within $\pm 20\%$ measurement accuracy of range during testing. EMC Regulatory Arrangement in Australia and New Zealand (RCM): EN 55011 Class A Group 1 compliant KC: Electromagnetic wave interference prevention standard, electromagnetic wave protection standard compliance	Only for the models with suffix code -x0x or -x2x.  For suffix code: -x0x, -x2x-, x3x, or -x4x, compliant with KC marking.
Hazardous area classification	FM nonincendive: Class 3600:2011 Class 3611:2004 Class 3810:2005 Locations: Class I, Division 2, Groups A,B,C and D Temperature Code: T4 CSA nonincendive: C22.2 No. 213-M1987 CAN/CSA-C22.2 No. 0-10 CAN/CSA-C22.2 No. 0.4-04 Locations: Class I, Division 2, Groups A,B,C and D Temperature Code: T4	For suffix code: -x0x and /FM or /CSA option, Nonincendive electric device usable in hazardous area.

Please select appropriate equipment in accordance with the laws and regulations of the relevant country/region, when it is used in a location where explosive atmospheres may be present.

### ● Notes regarding the safety standard



- 1) The standalone internal unit does not comply with the safety standard.  
Combination of the internal unit either with the safety standard compliance case or the safety standard compliance housing complies with the safety standard.
  - 2) For work involving taking out the internal unit or storing it in the case as described below, it is required to check safety in accordance with the safety standard (IEC/EN 61010-1).  
This work must be carried out by Yokogawa technicians or those authorized by Yokogawa, and testing (withstanding voltage test and the like) to check safety is required.  
If customers carry out the work at their own responsibility, the internal unit will no longer comply with the safety standard.
- [1] Work to take the internal unit out of the case, and work to put it back into the case or housing after it is replaced.  
[2] Work to replace and mount the power supply unit, display unit, or optional board.  
[3] Work to make changes to the setting switches on the main board and optional board.  
[4] Other maintenance and repair work involving taking out the internal unit.

### ■ ENVIRONMENT STANDARD

EU RoHS directive: EN IEC 63000  
(The /A08 option is excluded.)

■ Functional Block Diagram

● YS1350 functional block diagram

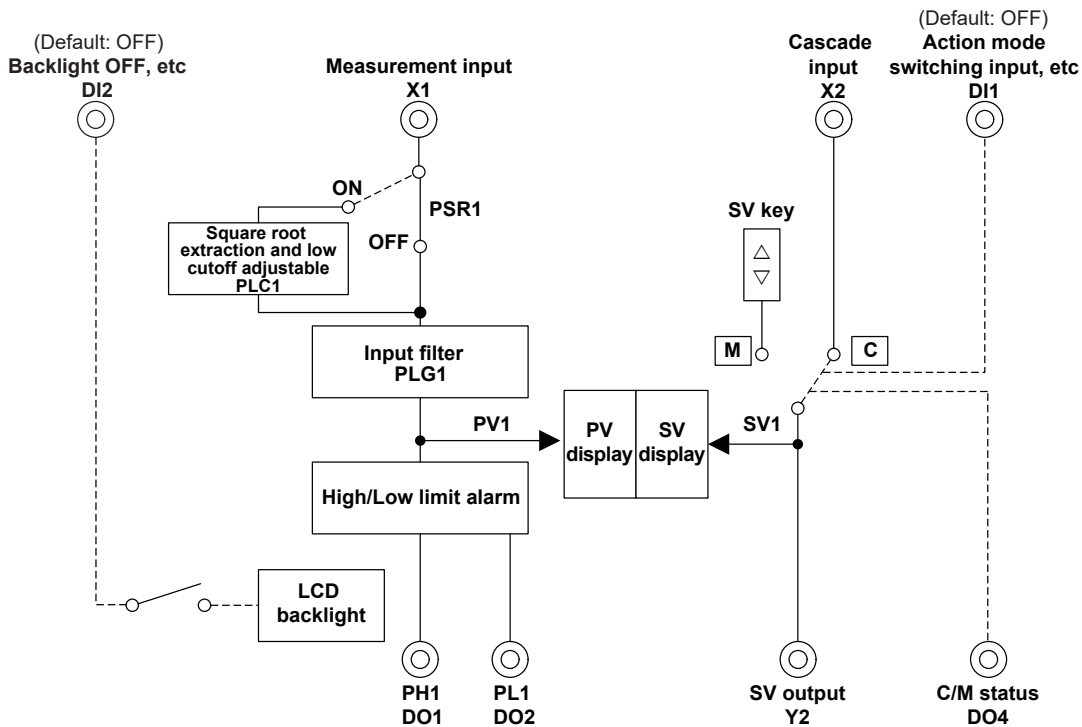

0101.ai

YS1350 functional block diagram

● YS1360 functional block diagram

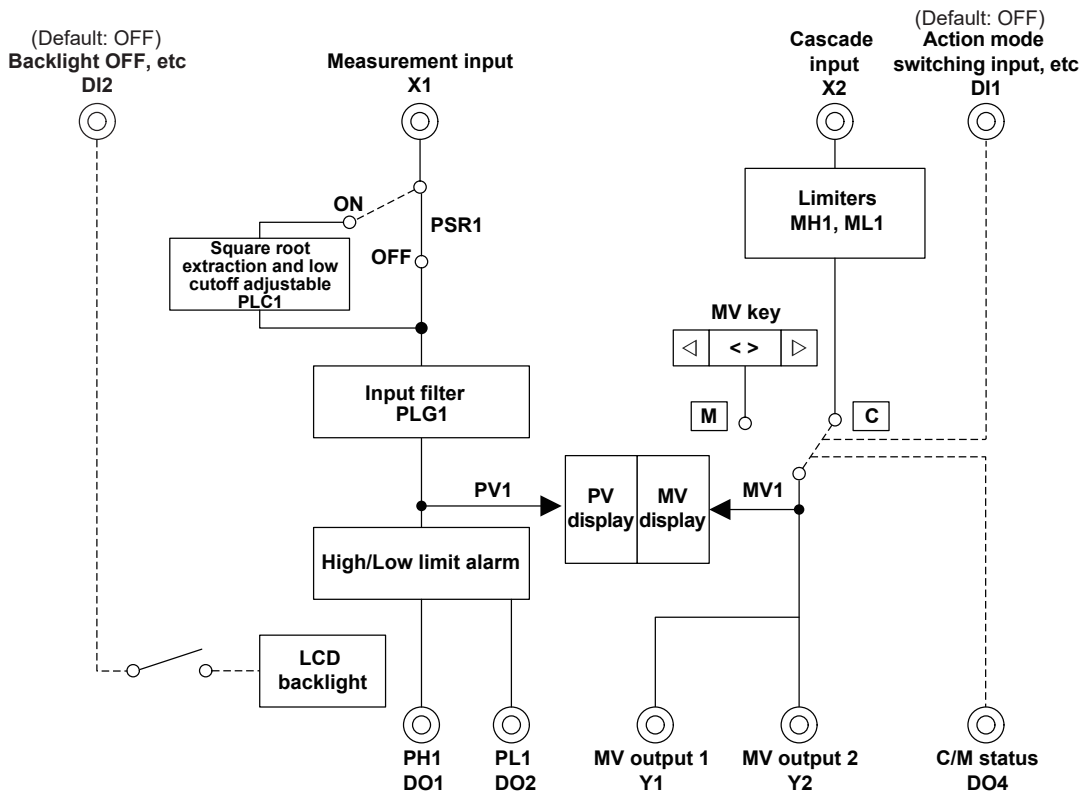

0102.ai

YS1360 functional block diagram

## Terminal Layout (Basic type)

Terminal Layout

Terminal No.	YS1350	YS1360
1	+ > Measurement input 1 (1-5V DC)	+ > Measurement input 1 (1-5V DC)
2	- >	- >
3	+ > Cascade input (1-5V DC)	+ > Cascade input (1-5V DC)
4	- >	- >
5	(*1)	(*1)
6		
7	(*1)	(*1)
8		
9	+ > Direct input signal output (*2)	+ > Direct input signal output (*2)
10	- >	- >
11	+ > Fail output	+ > Fail output
12	- >	- >
13	Transmitter Power supply (24V DC) (*3)	Transmitter Power supply (24V DC) (*3)
14	Communication SG	Communication SG
15	Communication SDA (-)	Communication SDA (-)
16	Communication SDB (+)	Communication SDB (+)
17	Communication RDA (-) or LCS (+)	Communication RDA (-) or LCS (+)
18	Communication RDB (+) or LCS (-)	Communication RDB (+) or LCS (-)
19	+ } Direct input (*4)	+ } Direct input (*4)
20	- }	- }
21		
22	(*1)	+ > MV output1 (4-20mA DC)
23		- >
24	+ > SV (1-5V DC)	+ > MV output2 (1-5V DC)
25	- >	- >
26	(*1)	(*1)
27		
28	+ > PV1 high limit alarm output	+ > PV1 high limit alarm output
29	- >	- >
30	+ > PV1 low limit alarm output	+ > PV1 low limit alarm output
31	- >	- >
32	(*1)	(*1)
33		
34	+ > C/M status output	+ > C/M status output
35	- >	- >
36	+ > Input for LCD backlight off	+ > Input for LCD backlight off
37	- >	- >
38	+ > Operation mode switching input	+ > Operation mode switching input
39	- >	- >
L	+ > Power supply	+ > Power supply
N	- >	- >
G	Ground (GND)	Ground (GND)

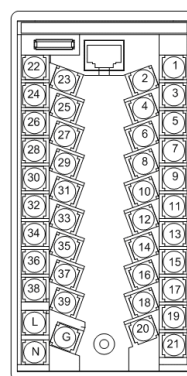

Direct Input Terminals

	Terminal number		
	19	21	20
2mV input (optional code /A01) 3Isolator (optional code /A05)	+	/	-
Thermocouple input (optional code /A02)			
RTD input (optional code /A03)	<p>Match the wiring resistances of terminals 19 and 21 with each other.</p>		
Potentiometer input (optional code /A04)	<p>Match the wiring resistances of terminals 19 and 20 with each other.</p>		
Frequency input (optional code /A08)	Two-wire type (voltage, contact)	+	-
	Power feed type, two-wired	Signal	Power Supply
Two-wire transmitter input (optional code /A06, /A07)	Power feed type, three-wired	+	-
	Supply voltage required		
Two-wire transmitter input (optional code /A06, /A07)	Case of 4 to 20 mA signal not requiring supply power		

Connection of Transmitter Power Supply

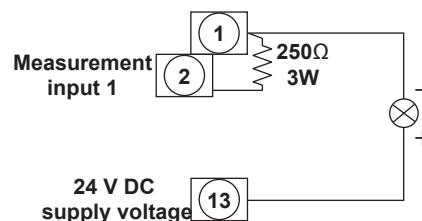

\*1: Do not connect.

\*2: If direct input (optional specifications) is provided, it becomes direct input signal output.

\*3: For connecting two wire transmitters: see "Connection of Transmitter Power Supply".

\*4: For direct input connection: see "Direct Input Wiring" described later.

## DIMENSIONS

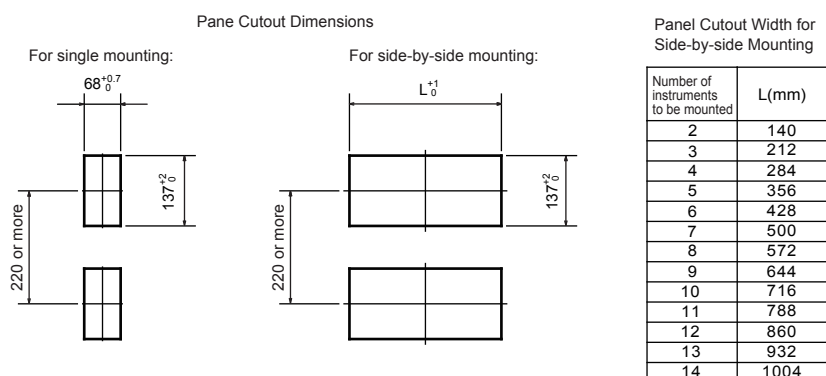
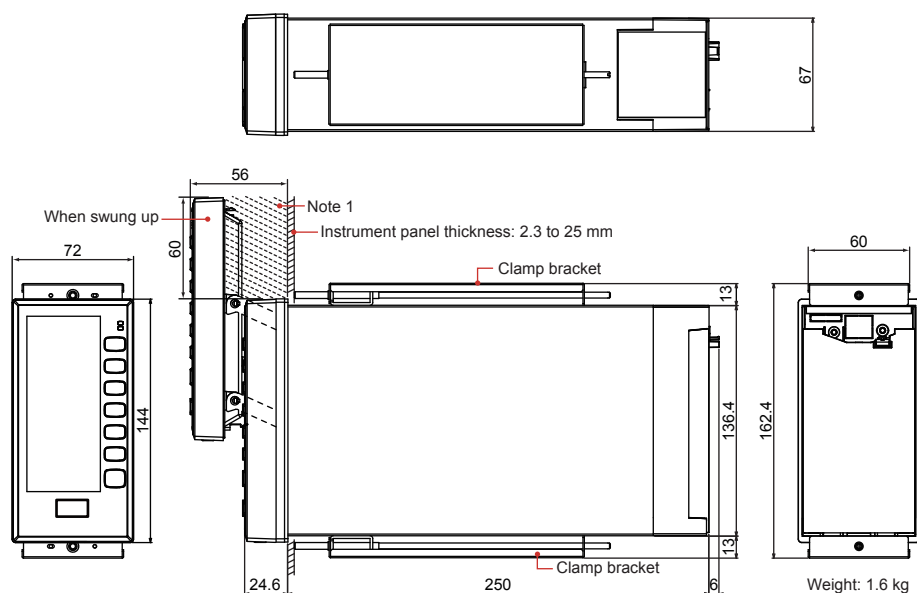

Trigonometry  
Unit: mm  
General tolerance =  $\pm$ (value of tolerance class IT18 based on JIS B 0401-1998) / 2

0908E.ai

\*1: When, for example, a rating plate is mounted within 60 mm or less of the top of the unit, the height shall be 300 mm or less from the panel surface.

\*2: An adequate space of 100 mm or more shall be provided under and over the panel to ensure ventilation.

\*3: For the YS100 compatible type, YS80 internal unit compatible type, EBS, I, EK, and HOMAC compatible types, YS80 compatible type, and 100 Line compatible type, refer to the relevant separate outline view.

## Structure, Mounting (Basic type)

Item		Specification
Structure		Front panel drip and dust proof structure (compliant with IP54). However, this structure cannot be used for side-by-side mounting instrumentation, and replacement types.
Mounting type		Indoor panel mounting
Panel mounting device		Mounting brackets to be used (at the top and bottom)
Panel cutout		137 <sup>+2</sup> x 68 <sup>+0.7</sup> (mm)
Connection method	External signal connection	M4 screw terminal connection
	Power supply and ground connection	M4 screw terminal connection
Dimensions		144 x 72 x 250 mm (height x width x depth from the panel)
Weight		1.6 kg

## ■ Model and Suffix Code

Model	Suffix Code	Optional Code	Remark
YS1350			Manual setter for SV Setting
YS1360			Manual setter for MV Setting
Use	-1		YS1350: Always -1 YS1360: With hard manual unit
	-2		YS1360 only: Without hard manual unit
Type	0		Basic type
	2		YS100 compatible type (with YS100 case)
	3		YS80 internal unit compatible type, EBS, I, EK, HOMAC compatible type (*1)
	4		YS80 compatible type (YS 80 compatible size, YS100 terminal type)
	5		100 Line compatible type (YS100 terminal type) (*2)
Power supply	0		100 VAC and 24 VDC common power supply
	1		220 VAC power supply
Direct input (*3)		/A01	mV input
		/A02	Thermocouple input
		/A03	Resistance temperature detector input
		/A04	Potentiometer input
		/A05	Isolator
		/A06	2-wire transmitter input (insulation type)
		/A07	2-wire transmitter input (non-insulation type)
		/A08	Frequency input (*9)
Communication		/DF	Direct input with Fahrenheit temperature range function (*8)
		/A31	RS-485 communication (PC link, Modbus, YS protocol) (*4)
		/A32	DCS-LCS communication (*5)
Certification		/A34	Ethernet communication (Modbus/TCP) (*6)
		/FM	FM nonincendive approved (FM Class I, Division 2) (*7)
	/CSA	CSA safety and nonincendive approved (Class I, Division 2) (*7)	

\*1: Can be connected with the YS80 housing (Model: SHUP-000). (The EK and HOMAC compatible housing SHUP-420 and EBS/I Series compatible housing SHUP-100 are available separately.)

\*2: The 100 Line compatible housing (Model: YS006) is available separately.

\*3: The direct input option can be added only for optional codes -x2x, -x4x, and -x5x. Multiple selections are not possible.

\*4: A combination with suffix code "-x3x" is not possible. Optional codes /A31 and /A32 cannot be simultaneously specified. Please specify the communication options /A31 (RS-485 communication) to directly communicate with the CENTUM CS3000/VP.

\*5: Optional codes /A31 and /A32 cannot be simultaneously specified. Please specify the communication options /A32 (DCS-LCS communication) to communicate with the CENTUM CS3000/VP through the SCIU.

\*6: Communication option /A34 can be specified only for suffix code -x0x.

\*7: Can be added only for suffix code -x0x.

\*8: This option can be combined only with option code /A02 or /A03. If option code /DF is specified, Fahrenheit temperature range can be available for direct input range in addition to Centigrade temperature range. In case of specifying Fahrenheit temperature range for direct input, option code /DF is required. When the direct input temperature range may be changed to Fahrenheit temperature range after shipment, also specify option code /DF.

\*9: When option code /A08 is specified, the conformity to CE marking is excluded.

## ■ Items to Be Specified at the Time of Ordering

Model, suffix code, and optional codes, when necessary, are required to be specified.

A tag number for the 12 alphanumeric symbols to be used on the main rating plate can be specified.

Direct input spec can be specified (only for the optional codes listed in the table below).

Optional Code	Item to Be Specified
/A01	Measurement range, Burnout
/A02	Thermocouple's compliance standard and type, Measurement range, Burnout
/A03	Resistance temperature detector's compliance standard, type, and resistance value at 0°C. Measurement range, Burnout
/A04	Total resistance, 0% resistance, 100% resistance, Burnout
/A08	Measurement range, Transmitter power supply (12 VDC/24 VDC), Input filter (ON/OFF), Current pulse load resistance (200 Ω, 500 Ω, 1 kΩ)

## ■ Accessories

Product Name	Part Number	Quantity	Remark
Clamp bracket	L4041RA	2	YS13x0-x0x
	E9760RJ	2	YS13x0-x2x
	E9760RN	2	
	E9760RJ	1	YS13x0-x4x
	E9760RP	1	
Tag plate seal	-	4	50x3.5mm
Range entry seal	-	4	34x2mm
RJC sensor	L3501RA	1	Can be used only with optional code /A02.
Ferrite core	A1179MN	1	For direct input cable (Supplied with products with optional code /A0x.)
M4 screw with spring washer	Y9408JH	42	YS13x0-x0x
YS1350 and YS1360 Operation Guide	-	1	A4-size

\* Product user's manuals can be downloaded or viewed at the following URL. To view the User's Manuals, use Adobe Acrobat Reader of Adobe Systems Incorporated.

<https://www.yokogawa.com/ns/ys/im/>

## ■ Accessories (sold separately)

Product name	Model	Remarks
SHUP standard housing	SHUP-000	Available for YS1xx0-x3x (Replace for YS80 Series)
SHUP long housing	SHUP-100	Available for YS1xx0-x3x (Replace for I Series or EBS Series)
SHUP EK/HOMAC housing	SHUP-420	Available for YS1xx0-x3x (Replace for EK or HOMAC Series)
100 Line pneumatic instrument replace housing	YS006	Available for YS1xx0-x5x (Replace for 100 Line pneumatic instrument)
120 $\Omega$ terminating resistor(*10)	YS020	For RS-485 communication
250 $\Omega$ shunt resistor	YS021	For a built-in 24 V transmitter power supply

\*10: The YS1350 or the YS1360 has a built-in terminating resistor, which can be selected for use by setting the relevant parameter. If a terminating resistor is used in another device at the termination of the same communication system, an external terminating resistor needs to be provided to match the terminating resistance of the YS1000's built-in terminating resistor.

## ■ Selection of Explosion Protected Equipment

Please select appropriate equipment in accordance with the laws and regulations of the relevant country/region, when it is used in a location where explosive atmospheres may be present.

## ■ Basic Conditions and Individual Contracts at the Time of Purchase

The warranty for this product is defined in the basic conditions and individual contracts at the time of purchase. The individual conditions are as follows.

- **Warranty period of firmware**

The warranty conditions for the firmware installed in this products are same as that of the hardware.